

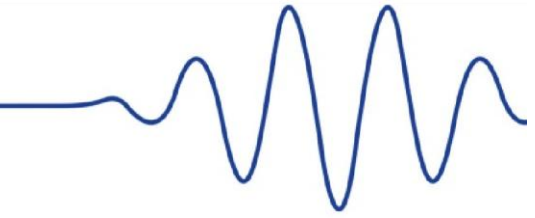

Radio Society of Great Britain

Advancing amateur radio since 1913



Radio Amateur Examinations Specification

For Examinations held from 1st April 2025

Publication date: 5th March 2026



Part 1 Introduction

Contents

1	Introduction	1.1
2	Syllabus	2.1
1	Licensing	2.1
2	Technical aspects	2.10
3	Transmitter and receivers	2.25
4	Feeders and Antennas	2.38
5	Propagation	2.46
6	Electro Magnetic Compatibility	2.51
7	Operating Practices and Procedures	2.60
8	Safety	2.66
9	Measurements and Construction	2.76
3	Foundation Licence Examination material	3.1
4	Intermediate Licence Examination material	4.1
5	Full Licence Examination material	5.1

Document changes.

Issue 1	December 2018	First issue to 2019 syllabus
Issue 1.1	February 2019	
Issue 1.2	July 2019	
Issue 1.3	July 2019	
Issue 1.4	July 2020	
Issue 1.5	Feb 2022	
Issue 1.5	Sept 2022	Editorial corrections only
Issue 1.5a	December 2023	Editorial corrections
Issue 1.6	March 2024	New licence conditions
Issue 1.6	April 2024	ESRG final edit
Issue 1.6a	July 2024	Foundation 1H1 correction
Issue 1.6b	Feb 2025	V1.6 First review
Issue 1.6b	Mar 2026	Minor edits

Minor revisions are examinable immediately as no new learning points are added

Major revisions are examinable after 6 months following publication

Introduction

The Radio Amateur Examinations Specification comprises a structured suite of three examinations designed to give access to the amateur radio bands. All prospective radio amateurs must demonstrate a suitable level of competence and proficiency as a pre-requisite to holding a licence.

The Foundation Licence is the entry level to amateur radio. Foundation training and examination is intended to provide an exciting introduction to the hobby.

The Intermediate Licence and examination continue the theoretical training to provide additional on-air privileges. It also provides a firm base from which to study for the Full level examination.

The Full level examination gives access to the Amateur Radio (Full) Licence which offers all licence privileges and is recognised internationally.

The aim of the suite of examinations is to verify and assure the regulator that successful candidates have

- knowledge of the legal and ethical requirements of amateur radio
- an understanding of safe working practices and are mindful of the safety of others
- a secure foundation for further study of radio science and technology
- knowledge of good operating practices and procedures
- an understanding of basic electronic components and systems relevant to amateur radio to a standard appropriate to the level of amateur radio licence addressed by each of the three examinations.

Key Features

- A progressive system of learning designed to promote an understanding of radio communications science, technology, and practice sufficient to allow the licensed operator to work safely on the amateur radio bands.
- Clear presentation of content for easy reference.
- The examination suite provides a backbone of theoretical knowledge whilst at the same time encouraging 'on-air' experience and practical skills.
- A course book is available at each level.
- Can be used within schools to enrich the Science and Technology curriculum.

The Assessment

Foundation level uses an examination comprising 26 questions lasting 60 minutes.

Intermediate level assessment consists of an examination comprising 46 questions lasting 1 hour 30 minutes.

Full level assessment consists of an examination comprising 58 questions lasting 2 hours.

Examinations will normally be taken on-line or, if this is not possible due to special educational needs or technical issues at the examination centre, on paper with an Optical Mark Sheet.

If the examination is taken on-line, the candidate receives their provisional result immediately at the end of the examination. Unless any examination irregularities are reported, this result will normally be officially confirmed after 6 working days. Exams taken on paper are centrally marked and results issued by post 6 clear working days after the papers are received¹. The results will also

¹ Candidates should allow 10 days from the examination to allow for postal delays.



Part 1 Introduction

be uploaded to the Ofcom licensing database. Candidates will use their candidate number and password to apply for their licence on-line on the Ofcom web site. A postal application option is available.

Prior Learning and Progression

There is no prior learning required at Foundation level and there are no set age limits to holding an Amateur Radio Licence. Some competence in mathematics will be required to sit the examination. Candidates may already be sufficiently proficient, or some aspects may need to be covered during the course. Details are given on page 7 under Prior Requirements.

Examinations must be sat in ascending order having achieved a pass at the previous level.

Training may commence at any time and students' progress through the three levels at their own pace. Candidates are encouraged to attend a suitable course but there is no obligation to do so.

There is no formal route of progression beyond Full level however there are many informal and academic opportunities for advancement and progression both in amateur radio and electronics generally. Possession of a Full Amateur Radio Licence is recognised as an advantage for entry into undergraduate training and many careers.

Candidates with disabilities

Arrangements can be made for candidates with disabilities to demonstrate their knowledge by whatever means is judged appropriate.

Applications for special arrangements should be made **well in advance** of the examination to the Radio Society of Great Britain (RSGB) and will normally require a medical or other professional certificate advising the appropriate method of assessment or examination. Any waiver granted will be shown on the Register and Assessment Sheet (RAS) issued by the RSGB Examination Department.

Appeals after the examination citing disabilities or learning difficulties not previously declared cannot be considered.

Examination Department
Radio Society of Great Britain
3 Abbey Court
Fraser Road
Priory Business Park
Bedford
MK44 3WH

The Syllabus

The syllabus is presented in three-column format showing the progression of each topic across all three examination levels.

The key words *Recall* and *Understand* are used to denote differing levels of comprehension.

Recall indicates the need to remember a fact and apply it fairly directly to a question or situation. A thorough understanding of why the fact is so and the full range of circumstances in which it is applicable is not required, but questions will expect a basic understanding of its meaning and implications.

Understand indicates the need for a more detailed knowledge of the subject, fully comprehending the reasons why the point is correct and the range of circumstances in which it is relevant and

Part 1 Introduction

applicable. Typically, this will be where the candidates will find themselves having to make judgements or apply a practice to a wider range of circumstances.

These terms should be read in the context of the level of the examination concerned.

At Foundation level there are more 'recall' syllabus items than 'understand' whereas at Full level the majority are of an 'understand' nature. That will expect the candidate to know the background to the topic and the implications of not adopting the accepted practice.

For example, at Foundation level the syllabus requires knowledge of the formula $P = V \times I$, what the letters stand for and the ability to perform a calculation given any two of the factors. The question will not normally require the use of a calculator since no useful purpose is served by making the question arithmetically difficult. Alternatively, the question may ask the effect of, for example, of doubling or halving one of the factors.

At Full level any Understand question may use calculations (+-x÷) if the context permits.

At any level of licence, particularly Full level, the incorrect operation of a relatively powerful transmitter can cause quite widespread interference to other radio users. Candidates at all levels will be expected to know in some detail how to operate correctly, what the effects of not doing so are and how to diagnose what might be wrong given such effects are occurring.

A statement of the mathematical abilities required to satisfactorily complete training at each level is shown in the *Mathematics and Symbols* paragraphs below. If candidates do not possess that level of skill at the outset, then its early acquisition is essential. Training courses need to recognise that need.

Examination Questions

At each level examination questions may assume background knowledge of the basic principles from all parts of any lower level syllabus and the current one although questions themselves will be clearly aimed at the relevant syllabus item.

Questions assume that the candidate holds the licence level for which they are being examined and questions referring to 'you' should be interpreted accordingly. Examination questions may not quote the Licence text verbatim.

It will also be assumed that the candidate has some familiarity with operating practices and procedures.

Some examination questions may refer to Schedule 1 and band plans. These are available as Exam Reference documents available on the RSGB website

Some time spent on-air either as a listener or as an amateur operator at Foundation or Intermediate level will be clearly advantageous in understanding the purpose and context of syllabus items and examination questions.

Allocation of Questions

Each item in the Syllabus is uniquely identified in its Heading e.g. 1A1. More than one syllabus item may be allocated to a question. The syllabus item will be randomly selected as will the individual question within that item when that examination is compiled.

Part 1 Introduction

Subject	Foundation	Intermediate	Full
Licensing conditions and station identification	6	6	7
Technical aspects	3	14	11
Transmitters and receivers	3	7	12
Feeders and antennas	3	4	4
Propagation	2	3	3
Electromagnetic compatibility	3	4	10
Good operating practices and procedures	3	2	2
Safety	3	3	4
Measurements and construction	-	3	5

Pass Mark

The Foundation level Pass Mark is 73% or 19 correct answers out of a total of 26 questions.

The Intermediate level Pass Mark is 61% or 28 correct answers out of a total of 46 questions.

The Full level Pass Mark is 60% or 35 correct answers out of a total of 58 questions.

Feedback

A feedback sheet will be produced for each candidate showing the selected syllabus item and the mark, correct or incorrect, for that question.

Formulae

At Foundation level it is important that candidates understand the fundamental principles behind the theoretical topics discussed. For that reason, no formula sheet is provided.

At Intermediate level formulae are provided but may need to be transposed.

At Full level, all formulae will be provided but are not titled or explained. Candidates will be expected to recognise which formula is appropriate and may need to transpose it depending on the parameter to be calculated.

The Reference data, including the formulae are contained in documents EX307 (Foundation), EX308 (Intermediate) and EX309 (Full) which can be downloaded from the RSGB web site. On-line candidates must have a clean copy of the appropriate Reference Data document at the start of the examination.

Language

The language of assessment will be English.

Training

Attendance at a training course is not compulsory but is very strongly advised.

Specimen Examination Question papers are available from the RSGB (www.rsgb.org).

Part 1 Introduction

Updates

Updates to this syllabus will be made from time to time and the latest version can be obtained from the RSGB website. Where the update involves a significant change to the syllabus content, the date from which the syllabus is valid for examinations will be amended to show the new period of validity of the syllabus. A minimum of three months' notice will be given. Minor syllabus changes, where the learning points have not been added are examinable immediately.

Tutors should note that all examinations will be in accordance with the syllabus which is current at the time of examination. Candidates must use only the information which will be provided in the examination, such as the licence schedule and band plan.

Any external changes, such as those affecting the licence will not be examinable until they have been formally announced as examinable. It should also be noted that the examination band plan is a specimen plan and not the live IARU/RSGB plan for on-air use.

Mathematics and Symbols

Some knowledge of mathematics will be required during any course and prior to the relevant examination. Tutors and candidates should address this requirement as necessary.

Foundation Licence

The following levels of knowledge and ability are needed by the time candidates are ready to take the Foundation Licence Examination.

Mathematical:

- Addition, subtraction, multiplication, and division.
- Simple fractions and their decimal equivalents.
- Multiple and sub-multiple units from micro to Giga.
- Conversion of numbers from 10^{-3} to 10^9 to/from decimal.
- Understanding of simple formulae, e.g. $I = V/R$, and rearrange them to make any parameter the subject of the formula.

Circuit Symbols and Diagrams:

- The symbols shown in Table 1 and the diagrams in Table 2 may be used in any examination item as required.

Intermediate Licence

The following levels of knowledge and ability as well as those at Foundation level are needed by the time candidates are ready to take the Intermediate Licence Examination.

Mathematical:

- Requirements of Foundation plus:
- Multiple and sub-multiple prefixes from Pico to Giga.
- Calculations with quantities from 10^{-12} to 10^{+12} recognising that interim stages may go outside those limits.
- Use of simple formulae containing brackets, squared or square root operators

e.g. $I = \sqrt{\left(\frac{P}{R}\right)}$ or $P = V^2/R$

Circuit Symbols;

- The symbols shown in Table 3 may be used in any examination item as required.



Part 1 Introduction

Full Licence

The following levels of knowledge and ability as well as those at Foundation and Intermediate levels are needed by the time candidates are ready to take the Full Licence Examination.

Mathematical:

- Requirements of Intermediate plus:
- Use and transposition of more complex formulae for example $f = \frac{1}{(2\pi\sqrt{LC})}$

Part 2 – The Syllabus

	Foundation	Intermediate	Full
	Section 1 — Licensing conditions and station identification		
	Nature of amateur radio, types of licence and call signs		
1A1	<p>Recall that the amateur licence is for self-training in radio communications and is of a non-commercial nature. Business use and commercial advertising is not permitted.</p> <p>Recall that the amateur licence permits operation in and over the United Kingdom, the Channel Islands and the Isle of Man in each case including their territorial seas.</p> <p>Recall that the amateur licence also authorises operation aboard ships or aircraft registered in the United Kingdom, the Channel Islands or the Isle of Man in international water or airspace.</p> <p>Recall that the licence does not permit use in other countries or their territorial waters or airspace.</p> <p><i>Notes: In practice a very low percentage of ships/aircraft are so registered and thus quite limited to the wider international arrangements for Full Licensees.</i></p> <p><i>Airborne use has limited power and is primary allocations only.</i></p> <p><i>Note. Refer to 7H1 for CEPT / International arrangements.</i></p>		

Part 2 – The Syllabus

	Foundation	Intermediate	Full
1A2	<p>Recall the various types of UK Amateur Licence.</p> <p>Recall that Regional Secondary Locators (RSLs), although optional, are defined in the licence and frequently used by amateurs to identify the location of their transmitting station.</p> <p>Recall the RSLs that may be used by individual amateurs: D, E, I, J, M, U, W</p> <p>Recall that the use of an RSL is mandatory for all 2x series callsigns.</p> <p>Recall that where an RSL is used, it must be used correctly.</p> <p>Understand that suffixes may be used (but must not be offensive or obscure correct identification)</p> <p>Recall that suffixes can optionally be used to indicate type of operation.</p> <p>Recall the restrictions applicable to Foundation Licensees in operation from a ship or aircraft.</p> <p><i>Note: The optional club secondary locators are not examined.</i></p>	<p>Recall the restrictions applicable to Intermediate licensees in operation from a ship or aircraft.</p>	

Part 2 – The Syllabus

	Foundation	Intermediate	Full
1A3	<p>Recall that the Licensee must give immediate notice to Ofcom of any change to the Licensee’s name and address quoted on the licence.</p> <p>Recall that the Licensee must confirm that the details shown on the licence remain valid at least once every five years.</p> <p>Recall that the licence can be revoked by Ofcom for breaches of licence conditions.</p>		
1A4	<p>Recall the requirements for station identification.</p> <p><i>Note: For the purposes of the examination this includes identifying when there is a change of:</i></p> <ul style="list-style-type: none"> • <i>frequency</i> • <i>mode, including change of digital protocols</i> • <i>FM (Frequency Modulation)</i> • <i>AM (Amplitude Modulation)</i> • <i>SSB (Single Sideband)</i> • <i>CW (Carrier Wave - Morse Code)</i> • <i>DATA (e.g. PSK, RTTY, WSPR, FT8)</i> • <i>Supervisor</i> • <i>Regional Secondary Locator, if used.</i> 		

Part 2 – The Syllabus

	Foundation	Intermediate	Full
	Operators and supervision		
1B1	<p>Recall that only the licensee, or any other person operating under the licensee’s direct supervision, may use the Radio Equipment.</p> <p>Recall that the call sign of the supervisor is used to identify the station and operation is in accordance with the supervisor’s licence.</p> <p>Recall that in certain circumstances the licensee may allow the equipment to be used by a member of a User Service.</p> <p><i>Notes:</i></p> <p><i>The term ‘Radio Equipment’ (in initial capitals) is a defined licence term meaning the equipment used and identified by the operator’s call sign. If a visiting amateur uses the radio equipment with their own call sign, it is then deemed to be their Radio Equipment.</i></p> <p><i>The nature of the circumstances and identity of the User Service are not examinable.</i></p>	<p>Understand the meaning of direct supervision, duties of the supervisor and need for the operator to comply with the licence.</p>	

Part 2 – The Syllabus

	Foundation	Intermediate	Full
	Messages		
1C1	<p>Recall the requirements to send messages only to other amateur radio stations and only using UK Amateur frequencies.</p> <p>Recall that a 'Net' or 'Network' refers to transmissions to three or more Amateurs with whom communication and identification has been established.</p> <p>Recall that transmitting for general reception, that is to anybody who may be listening, is not permitted other than for CQ calls.</p>	<p>Recall that in an international disaster messages may be passed, internationally, on behalf of non-licensed persons.</p>	<p>Understand the requirements relating to the content of messages and who messages may be sent to.</p> <p>Understand the circumstances when messages, including encrypted content, may be sent.</p> <p>Understand the distinction between the use of codes and abbreviations and encryption.</p> <p>Understand that people of all ages and backgrounds participate in amateur radio and that messages must not cause offence, particularly in the context of relevant legislation including the Wireless Telegraphy (Content of Transmission) Regulations 1988 and the Communications Act (2003).</p>
1C2	<p>Recall that encryption is not permitted except at the direct request of a User Service or for control of amateur satellites</p> <p><i>Note: Morse code is not a secret code and that it is only secret codes which obscure the meaning of the Message that are prohibited.</i></p>	<p>Recall that the licensee may pass messages on behalf of a User Service and may permit them to use the Radio Equipment to send messages.</p>	

Part 2 – The Syllabus

	Foundation	Intermediate	Full
	Apparatus, inspection and closedown		
1D1	<p>Recall the Licensee must ensure that the station is not causing Undue Interference to other radio users.</p> <p>Recall that a person authorised by Ofcom has the right to any or all the following:</p> <ul style="list-style-type: none"> • Inspection of, • require the modification of, • require the closedown of, • restrict the operation of, <p>the Radio Equipment.</p>	<p>Recall that transmissions from the station must not cause undue interference to other radio users.</p> <p>Recall that the Licensee must reduce any emissions causing interference, to the satisfaction of a person authorised by Ofcom.</p> <p>Understand that this may include a reduction in transmit power or any other action required to reduce emissions to an acceptable level.</p>	<p>Understand the requirements for clean and stable transmitters.</p> <p>Understand the need to avoid Undue Interference to other wireless telegraphy.</p> <p>Understand the role of Ofcom in cases of Undue Interference.</p>
1D2	<p>Recall that a person authorised by Ofcom may require the Licence holder to keep a log of all transmissions made over a specified period of time.</p>	<p>Recall the occasions for mandatory log keeping.</p> <p>Understand circumstances in which modification or cessation of operating of the station may be required.</p> <p>Understand circumstances in which modification of transmitting equipment may be required.</p>	

Part 2 – The Syllabus

	Foundation	Intermediate	Full
	Unattended and remote control operation		
1E1		<p>Recall that the licensee may use any communication link for the purposes of Remote Control of their station and must ensure that:</p> <ul style="list-style-type: none"> • any links used for the Remote Control of the Radio Equipment must be adequately secure so as to ensure that no other person is able to control the Radio Equipment; • Remote Control links using Amateur Radio frequencies must use frequency bands above 30 MHz and must not be encrypted; • transmissions from the Radio Equipment can be terminated promptly; and • the Licence Number must be displayed on or next to any unattended Radio Equipment located other than at the address shown in the licence. 	

Part 2 – The Syllabus

	Foundation	Intermediate	Full
	Electromagnetic Fields		
1G1	<p>Recall the</p> <ul style="list-style-type: none"> • purpose of basic EMF restrictions; • equipment to which the EMF restrictions apply; • transmit power level at which the EMF restrictions apply; • persons to which the EMF restrictions apply; • need to keep a record of assessments carried out. <p><i>Note:</i></p> <p>1. See also 8D1. 2. The record includes a justification of why no further action is required if that is the case (e.g., power levels are below the threshold)</p>	<p>Recall</p> <ul style="list-style-type: none"> • the average and peak transmit power level at which the EMF restrictions apply; • when there is a need to reassess EMF compliance. 	<p>Understand relevant information in the licence.</p> <ul style="list-style-type: none"> • Origin of the EMF restrictions (ICNIRP); • Meaning of the term ‘general public’; • Areas in which the general public need to be protected from EMF in breach of the limits; • Records of EMF assessment; • Procedure for carrying out an EMF assessment; • Emergency situations.
	Licence Schedule		
1H1	<p>Identify relevant information in Schedule 1 to the Foundation licence.</p> <p>Recall the difference between Primary and Secondary status and that other services may also be present with such status in some allocations.</p> <p><i>A copy of the relevant part of Schedule 1 will be available during the examination.</i></p>	<p>Identify relevant information in Schedule 1 to the Intermediate licence.</p> <p><i>A copy of the relevant part of Schedule 1 will be available during the examination.</i></p>	<p>Identify relevant information in Schedule 1 – frequencies less than 30MHz</p> <p>Identify relevant information in Schedule 1 – frequencies greater than 30MHz</p> <p>Identify relevant information in Schedule 1 - Notice of Coordination</p> <p><i>A copy of the relevant part of Schedule 1 and the Notice of coordination will be available during the examination.</i></p>

Part 2 – The Syllabus

	Foundation	Intermediate	Full
	Section 2 — Technical aspects		
	Fundamental theory		
2A1	<p>Understand that the flow of electrons is an electric current.</p> <p>Recall that a conductor allows electrons to flow easily and that an insulator does not.</p> <p>Recall that metals such as copper and brass are good conductors, as is carbon. Plastics, rubber, glass and ceramics are regarded as insulators.</p> <p>Recall that current can flow across wet insulators.</p> <p>Recall that the unit of electric current is the Ampere (Amp).</p> <p>Recall that the unit of electrical potential is the Volt.</p>	<p>Recall that components have tolerances, and that the measured value of a component may not precisely agree with its marked value.</p>	<p>Understand component tolerances and the effects they may have in circuit operation.</p>
2A2	<p>Recall that a circuit is needed to allow current to flow, and that circuit will include a source of electrical energy.</p> <p>Recall that current in all parts of a series circuit has the same value.</p> <p>Recall that the potential differences across items in parallel are the same.</p>		

Part 2 – The Syllabus

	Foundation	Intermediate	Full
	Power		
2B1	<p>Recall that power is measured in Watts (W).</p> <p>Recall that a current through a resistor results in conversion of electrical energy to heat energy in the resistor.</p> <p>Understand that Power (Watts) in a circuit is the product of the Potential Difference (Voltage) and the Current (Amps) i.e. $P=V \times I$</p> <p>Calculate the unknown quantity given the numerical value of the other two.</p>		<p>Solve series/parallel resistor circuits to calculate currents, voltages, resistances and power given appropriate values. This may include the use of series/parallel formulae, Ohm's Law and power.</p> <p><i>Equations include $P=V^2/R$ and $P=I^2 \times R$</i></p>
	Resistance		
2C1	<p>Understand that resistance is the property of a material that opposes the flow of electricity.</p> <p>Recall that the unit of resistance is the Ohm (Ω).</p> <p>Recall that the current (I) through a resistor (R) is proportional to the voltage (V) across that resistor.</p> <p>Use Ohm's law to calculate the value of any one of the three quantities (voltage V, current, I and resistance R) given the other two.</p> <p>Understand that where a supply feeds more than one component or device the total current is the sum of the currents in the individual items when connected in parallel.</p>	<p>Understand circuits comprising series and parallel connections of resistors and cells.</p> <p>Calculate the value of any one of the three quantities (V, I or R) given the other two.</p> <p>Calculate the combined resistance of two or three resistors in series and/or parallel.</p> <p><i>Resistors of different values may be used in series or parallel or combined series parallel circuits.</i></p> <p><i>The prefixes milli and kilo may be involved for some of these calculations.</i></p>	

Part 2 – The Syllabus

	Foundation	Intermediate	Full
2C2	Understand that the sum of the voltages across a number of resistors in series equals the supply voltage.	Understand that two or three resistors can be arranged to act as a potential divider and apply the formula. <i>The prefixes milli and kilo may be involved for some of these calculations.</i>	
2C3		Understand the difference between potential difference (PD) and electromotive force (EMF). Understand the concept of source resistance (impedance) and voltage drop due to current flow.	
2C4	Recall that polarity must be correct for electronic circuits to function correctly, or damage may be caused.		
	Reactive components		
2D1		Recall that a capacitor normally consists of two metal plates separated by an insulating material and that its capacitance is measured in Farads. Understand that a capacitor can store an electric charge, and that its ability to store a charge (capacitance) depends upon the area of the plates, their separation and the nature of the material between the plates (the dielectric).	Understand the factors influencing the capacitance of a capacitor; area and separation of the plates, permittivity of dielectrics and formula $C=k \times A/d$. Recall that the Coulomb is the quantity of electricity, Q, given by current \times time and that the charge on a capacitor is given by $Q = V \times C$.
2D2		Understand and apply the formulae for calculating the combined values of two or three capacitors in series and in parallel.	Recall that different dielectrics are used for different purposes, e.g. air, ceramic, mica and polyester; and that with some dielectrics, losses increase with increasing frequency.

Part 2 – The Syllabus

	Foundation	Intermediate	Full
2D3		Recall that some capacitors e.g. electrolytic are polarised and must be correctly connected to avoid injury, damage or destruction.	Understand that capacitors have a breakdown voltage and that they need to be used within that voltage.
2D4		<p>Understand the relative movement of a conductor in a magnetic field will induce a voltage across the ends of the conductor.</p> <p>Recall that a current passing through a wire forms a magnetic field around the wire.</p> <p>Recall that an inductor is normally a coil formed of a number of turns of wire to concentrate the magnetic field and that inductance is measured in Henries.</p> <p>Recall that an inductor is able to store energy in its magnetic field.</p> <p>Recall that the ability to store energy is known as inductance, which depends upon the number of turns of wire on the coil and its dimensions.</p>	Understand the term 'self-inductance' and recall that a 'back EMF' is produced as current flow changes in an inductor.
2D5		Understand and apply the formulae for calculating the combined values of two or three inductors in series and in parallel.	
2D6		<p>Recall that the inductance of a coil increases with increasing number of turns, increasing coil diameter and decreasing spacing between turns.</p> <p>Understand the use of high permeability cores and slug tuning.</p>	

Part 2 – The Syllabus

	Foundation	Intermediate	Full
2D7			<p>Understand the rise and fall of current in an LR circuit and that the time constant $t = L/R$.</p> <p>Understand the rise and fall of voltage in a CR circuit and that the time constant $t = C \times R$.</p>
	AC theory		
2E1	Understand what is meant by Direct Current (DC) and Alternating Current (AC).	Understand that by repeatedly charging and discharging in alternate directions, a capacitor can pass alternating currents but cannot pass a direct current.	
2E2	<p>Identify the sine wave as a graphical representation of the rise and fall of an alternating current or voltage over time.</p> <p>Recall the frequency of the mains supply – 50Hz.</p> <p>Recall the range of frequencies for normal hearing – 20Hz -15kHz.</p> <p>Recall the range of frequencies for audio communication – 300Hz - 3kHz.</p> <p>Recall that radio frequencies can range from below 30kHz to beyond 3000MHz.</p> <p>Recall the frequency bands for HF, VHF and UHF radio signals.</p> <p>Understand the meaning of the abbreviations RF and AF.</p>	<p>Understand the sinusoidal curve as a graphical representation of the rise and fall of an alternating current or voltage over time and that both the frequency and the amplitude must be specified.</p> <p>Recognise the graphical representation of a square wave.</p> <p>Recall that the time in seconds for one cycle is the Periodic Time (T) and the formula $T=1/f$ and $f= 1/T$ where f = frequency in Hertz.</p> <p>Recall the concept of phase difference between two signals, and that it can be expressed in degrees.</p>	

Part 2 – The Syllabus

	Foundation	Intermediate	Full
2E3		<p>Recall that the potential difference across and current through a resistor are in phase.</p> <p>Recall that the power dissipated in a resistive circuit varies over the cycle.</p> <p>Recall that the RMS current or voltage in an AC circuit is equal to the current or voltage of a DC supply that would result in the same power dissipation.</p> <p>Recall that the RMS value of a sinusoidal waveform,</p> $V_{rms} = 0.707 \times V_p \text{ (peak Voltage)}$ <p>Perform relevant calculations.</p> <p>Recall that the term 'Reactance' describes the opposition to current flow in a purely inductive or capacitive circuit where the phase difference between V and I is 90°.</p>	<p>Understand that current lags potential difference by 90° in an inductor and that current leads by 90° in a capacitor.</p> <p>Understand the formulae for the reactance of a capacitor or inductor in terms of the frequency and component value.</p> <p>Calculate the unknown term given the other two.</p>
2E4		<p>Recall that the ratio of the RMS potential difference to the RMS current as the capacitor stores energy in its electric field is called the reactance of the capacitor and is measured in ohms.</p> <p>Understand that the reactance of a capacitor depends on the frequency of the alternating current and that the reactance falls as the frequency rises.</p> <p>Identify the graph of reactance against frequency for the capacitor.</p>	<p>Understand the use of capacitors for AC coupling (DC blocking) and decoupling AC signals (including RF bypass) to ground.</p>

Part 2 – The Syllabus

	Foundation	Intermediate	Full
2E5		<p>Recall that an inductor will take time to store or release energy in its magnetic field.</p> <p>Recall that the ratio of the RMS potential difference to the RMS current as the inductor stores energy in its magnetic field is called the reactance of the inductor and is measured in ohms.</p> <p>Understand that the reactance of an inductor depends on the frequency of the alternating current and that the reactance rises as the frequency rises.</p> <p>Identify the graph of reactance against frequency for the inductor.</p>	<p>Understand the use of inductors for DC decoupling (AC blocking).</p>
2E6		<p>Recall that in a circuit comprising resistors and capacitors or inductors (or both) a current will result in energy transfer into heat in the resistors and energy storage and release in the capacitors or inductors.</p> <p>Recall that in such a circuit the ratio of the overall potential difference to current is termed 'impedance' and that this name denotes an opposition to both energy transfer and energy storage in the circuit.</p> <p>Recall impedance is measured in ohms.</p> <p><i>Note: Phase and vector notation is NOT included at this level.</i></p>	<p>Understand that impedance is a combination of resistance and reactance and apply the formula for impedance and current in a series CR or LR circuit.</p>

Part 2 – The Syllabus

	Foundation	Intermediate	Full
2E7	<p>Understand the relationship between frequency (f) and wavelength (λ).</p> <p>Recall the units for frequency (Hz) and wavelength (m).</p> <p><i>Both the $f \lambda$ graph and the velocity of radio waves will be given in the Reference Booklet.</i></p>	<p>Recall and manipulate the formula $v = f \times \lambda$.</p> <p>Calculate frequency or wavelength given the other parameter.</p> <p><i>The velocity of radio waves will be given in the Reference Booklet.</i></p>	
2E8		<p>Understand that where a conductor is carrying an RF signal which has a wavelength comparable to the length of the conductor that the magnitude and direction of the current and voltage at any point in time will vary in a sinusoidal manner along the length of the conductor.</p>	
	Digital signals		
2F1	<p>Recall that analogue signals are constantly changing in amplitude, frequency or both.</p> <p>Recall that digital signals are a stream of finite values at a specific sampling interval.</p> <p>Recall that digital signals can be processed by a computing device with suitable software.</p>	<p>Recall that digital signals with more bits and/or increased sampling rate enables a more accurate representation of the analogue signal.</p> <p>Recall that the error introduced by sampling the analogue signal to produce the digital signal is a form of distortion.</p> <p>Recall that the minimum sampling rate needs to be greater than twice the frequency of the analogue signal to adequately capture the detail of the analogue signal being sampled.</p> <p>Recall that the minimum sampling rate is known as the Nyquist rate.</p>	<p>Understand that analogue to digital conversion can generate a false image of the signal if frequencies are present above the frequency which is half the sampling (Nyquist) rate.</p> <p>Recall that these false images are known as aliases.</p> <p>Understand that anti-aliasing filters are used to avoid this occurring.</p>

Part 2 – The Syllabus

	Foundation	Intermediate	Full
2F2	<p>Recall that an Analogue to Digital Convertor (ADC) is a device used to sample an analogue signal and produce a digital representation of it.</p> <p>Recall the meaning of the term ADC.</p> <p>Recall that a computing device is required to process digital signals.</p> <p>Recall that a Digital to Analogue Convertor (DAC) is a device used to represent a digital signal in analogue format.</p> <p>Recall the meaning of the term DAC.</p>		<p>Recall that digital signals in the time domain can be depicted in the frequency domain by using a mathematical operation known as a Fourier Transform (FT).</p> <p>Recall that a Fourier Transform takes digital signals in the time domain and calculates the amplitudes and the frequencies which comprised the original signal.</p>

Part 2 – The Syllabus

	Foundation	Intermediate	Full
	Transformers		
2G1		<p>Understand that a simple transformer consists of two coils of wire sharing the same magnetic field.</p> <p>Recall that it may have an iron core to concentrate the field.</p> <p>Understand that at higher frequencies (e.g. RF and IF) a ferrite core, rather than an iron core, is used for improved efficiency.</p> <p>Understand that energy is transferred from one coil to the other by changes in the field when alternating current is used, and that this does not happen with constant direct current.</p> <p>Understand that an alternating potential difference (such as the mains) can be stepped down using fewer turns of wire on the secondary coil than the primary and can be stepped up using more turns on the secondary than on the primary</p> <p>Understand that the output from a transformer will always be an alternating current.</p> <p><i>Note: Note that knowledge of the impedance change is not required.</i></p>	<p>Understand the concept of mutual inductance.</p> <p>Understand and apply the formulae relating transformer primary and secondary turns to primary and secondary potential differences and currents.</p> <p>Understand the impedance change in a transformer and apply the formula relating transformer primary and secondary terms to primary and secondary impedances.</p> <p>Recall that different magnetic materials used as cores for inductors and transformers perform best over different frequency ranges and affect their efficiency.</p> <p>Recall that losses in the material will cause heating which affects power handling and the required physical size of the core for the power concerned.</p>

Part 2 – The Syllabus

	Foundation	Intermediate	Full
	Tuned Circuits and resonance		
2H1		<p>Recall that a series or parallel circuit of a capacitor and inductor together forms a tuned circuit.</p> <p>Recall, using graphical methods, that at resonance the reactance of the capacitance will equal the reactance of the inductance, $X_C = X_L$.</p>	<p>Apply the formula for the resonant frequency of a tuned circuit to find values of f, L or C from given data.</p>
2H2		<p>Recall that, at their resonant frequencies, series tuned circuits present a low impedance, whereas parallel tuned circuits present a high impedance.</p> <p>Identify the response curves of impedance vs frequency for series and parallel resonant circuits.</p>	<p>Recall the equivalent circuit of a crystal and that it exhibits series and parallel resonance.</p> <p>Recall that crystals are manufactured for either series or parallel operation and will only be stable and correct on the marked frequency when used in the intended manner.</p>
2H3		<p>Recall that the energy stored in the capacitor and inductor in a tuned circuit can transfer from one to the other at a particular frequency, known as the resonant frequency.</p> <p>Recall how the resonant frequency depends on the value of capacitance and inductance.</p> <p><i>Note that candidates must know that increasing L or C reduces the resonant frequency and vice-versa.</i></p> <p><i>Knowledge of the resonant frequency formula is not required.</i></p>	

Part 2 – The Syllabus

	Foundation	Intermediate	Full
2H4		<p>Recall that selectivity of a tuned circuit is the ratio of the bandwidth of the circuit (that is the range of frequencies the circuit will accept) to the resonant frequency.</p> <p>Recall that the Q factor of a tuned circuit is an indication of the selectivity of the tuned circuit.</p>	<p>Understand the concept of the magnification factor Q as applied to the voltages and currents in a resonant circuit.</p> <p>Recall that voltages and circulating currents in tuned circuits can be very high and understand the implications for component rating.</p> <p>Apply the formula for Q factor given circuit component values.</p> <p>Recall the definition of the half power point of resonance curves.</p> <p>Apply the equation for Q given the resonant frequency and the half power points on the resonance curve.</p>
2H5		<p>Identify the circuits of simple low pass, high pass, band pass and band stop (notch) filters and their response curves.</p> <p>Recall, using graphical methods, the concept of the cut-off frequency.</p>	<p>Understand the meaning of dynamic resistance, R_D.</p>
	Semiconductor devices		
2I1		<p>Recall that a diode will conduct current in one direction only.</p> <p>Recall that a diode junction has a depletion layer and that a voltage must be applied to overcome this and allow current to flow (forward bias).</p> <p>Understand the use of a diode to produce direct current from an alternating current is known as rectification.</p>	<p>Recall that a Zener diode will conduct when the applied reverse bias potential is above its designed value and identify its V/I characteristic curve.</p>

Part 2 – The Syllabus

	Foundation	Intermediate	Full
212		<p>Recall that a variable capacitance diode behaves like a capacitor when reverse biased and that the capacitance of a reverse biased diode depends on the magnitude of the reverse bias.</p>	
213		<p>Understand that a bipolar junction transistor is a three terminal device (emitter, base, collector) in which a small base current will control a larger collector current and this enables the transistor to be used as an amplifier.</p> <p>Understand that the ratio of the collector current to the base current (I_C/I_B) is the current gain β or h_{FE} of the transistor.</p> <p>Understand that if the variation in the base current is large enough the collector current can be turned on and off and the transistor behaves as a switch.</p> <p><i>Note: the candidate is not required to recall transistor configurations.</i></p> <p><i>Circuits shown will be an NPN transistor connected in common emitter mode.</i></p>	<p>Understand the basics of biasing NPN and PNP bipolar transistors and field effect transistors (FET) (including dual gate devices).</p>
214		<p>Recognise the circuit of a simple common emitter amplifier.</p> <p>Recall that semiconductors must be provided with the correct DC voltages and currents to allow them to function and that this is termed biasing.</p> <p><i>Note that calculations are not required.</i></p>	<p>Identify different types of small signal amplifiers (e.g. common emitter (source), emitter follower and common base) and explain their operation in terms of input and output impedances, current gain, voltage gain and phase change.</p> <p>Recall the characteristics and typical circuit diagrams of different classes of amplifiers (i.e. A, B, A/B and C).</p>

Part 2 – The Syllabus

	Foundation	Intermediate	Full
215		<p>Recall that a transistor can be used to generate audio and radio frequencies by maintaining the oscillations in a tuned or frequency selective circuit.</p> <p>Distinguish between a crystal oscillator and a variable frequency oscillator (VFO) based on a tuned circuit.</p> <p><i>Note: Diagrams will show the Colpitts oscillator with the transistor in emitter follower mode.</i></p> <p><i>Candidates are not expected to recognise other types of oscillator.</i></p>	<p>Understand the feedback requirements to sustain oscillations in an oscillator. With reference to gain, phase and feedback losses.</p>
216		<p>Recall that many individual semiconductor devices may be built on a common substrate and packaged as an integrated circuit (IC).</p> <p>Recall that ICs may provide complete circuit functions, including, amplifiers, oscillators, voltage regulators and digital processing chips in a single package.</p> <p><i>Questions will be limited to the IC applications shown above.</i></p>	

Part 2 – The Syllabus

	Foundation	Intermediate	Full
	Cells and power supplies		
2J1	<p>Understand that a battery is a combination of cells (usually in series).</p> <p>Recall that a battery provides electrical energy from stored chemical energy and has a Potential Difference across its terminals.</p> <p>Recall that any unwanted battery must be properly disposed of.</p> <p>Understand that a rechargeable (secondary) battery has a reversible chemical process.</p>	<p>Recall that different technologies used in cells give different terminal voltages.</p> <p>Recall that battery capacity (stored charge) is measured in Ampere-hours (Ah).</p>	
2J2		<p>Recall the circuit diagrams and characteristics of different types of rectifier and smoothing circuit (i.e. half wave, full wave and bridge).</p>	<p>Understand the function of stabilising circuits and identify different types of stabilising circuits (i.e. Zener diode/pass transistor and IC).</p> <p><i>Note: questions on the characteristics of individual components are covered in other parts of this syllabus. This subsection is on complete circuits.</i></p>
2J3		<p>Understand that in a rectifier circuit a reservoir capacitor can store a charge during the conducting part of the cycle and release it during the non-conducting part, providing a smoothing effect and a smoother DC output.</p> <p>Identify the AC and rectified (pulsed DC) waveforms.</p>	<p>Understand the need for rectifier diodes to have a sufficient peak inverse voltage (PIV) rating and calculate the PIV in diode/capacitor circuits.</p>

Part 2 – The Syllabus

	Foundation	Intermediate	Full
2J4		<p>Identify discrete component and integrated circuit linear power supplies and understand the basic principle of their operation.</p> <p>Recall the relative merits of linear and switched mode power supplies. Size, efficiency, heat, input and output voltage, RFI, cost & weight.</p>	<p>Understand the basic principles and operation of a switch mode power supply, at block diagram level.</p>

Part 2 – The Syllabus

	Section 3 — Transmitters and receivers		
	Transmitter concepts		
3A1	<p>Recall that the function of a radio transmitter is to send information from one place to another using electromagnetic radiation/wireless technology.</p> <p>Recall that the process of adding information to a radio frequency carrier is known as modulation.</p>		
3A2	<p>Recall that the audio (or data) signal is modulated on to the radio frequency carrier in the modulation stage of the transmitter.</p> <p>Recall that modulation is achieved by varying the amplitude or frequency of the carrier, resulting in AM or FM modulation modes.</p> <p>Recall that information can be carried by AM, SSB or FM.</p> <p>Recall that data may be transmitted by modulating the carrier using suitable audio tones, commonly two or more, generated by an audio interface such as a computer sound card.</p>	<p>Recall the meaning of depth of modulation for amplitude modulation.</p> <p>Recall the meanings of wide band and narrow band frequency modulation.</p> <p>Recall the meaning of the term Peak Deviation.</p>	<p>Recall the meaning of Modulation Index and its effect on the number of FM sidebands.</p>

Part 2 – The Syllabus

<p>3A3</p>	<p>Recall that when radio frequencies are modulated (mixed) with an audio frequency the new frequencies that are generated are called sidebands.</p> <p>Recall that amplitude modulated signals contain two sidebands and the carrier.</p> <p>Recall that a SSB modulated signal contains only one sideband.</p>	<p>Understand that single sideband (SSB) is a form of amplitude modulation where one sideband and the carrier have been removed from the transmitted signal.</p> <p>Understand that SSB is more efficient than AM or FM because power is not used to transmit the carrier and the other sideband.</p> <p>Understand that a second advantage is that the transmitted signal takes up only half the bandwidth, e.g. 3kHz not 6kHz.</p> <p>Recall that :</p> <ul style="list-style-type: none"> • AM uses less bandwidth than FM • SSB uses less bandwidth than AM • CW uses less bandwidth than SSB. Some digital modes may use less bandwidth than any of the above. 	
<p>3A4</p>	<p>Identify diagrams representing audio, an RF carrier, amplitude modulated, frequency modulated and CW radio signals.</p> <p>Understand the terms carrier, audio waveform and modulated waveform.</p> <p><i>Note: Table 2 shows appropriate diagrams.</i></p>		
	<p>Transmitter architecture</p>		
<p>3B1</p>	<p>Identify the items in a simple transmitter block diagram and recall their order of interconnection: Microphone, audio (microphone) amplifier stage, frequency generation stage, modulator stage, RF power amplifier stage, feeder and antenna.</p>	<p>Understand the block diagrams of CW, AM, SSB and FM transmitters.</p>	<p>Understand the block diagram of an SSB transmitter employing mixers to generate the final frequency.</p> <p>Understand the block diagram of an FM transmitter employing either frequency multipliers or mixers to generate the final frequency.</p>

Part 2 – The Syllabus

	Oscillators		
3C1	<p>Recall that the oscillator in a simple transmitter sets the frequency on which the transmitter operates.</p> <p>Recall that incorrect setting of this stage can result in operation outside the amateur band and interference to other users.</p>	<p>Recall and understand the relative advantages and disadvantages of a crystal oscillator and a VFO.</p> <p>Recall that the resonant frequency of the tuned circuit in a VFO determines the frequency of oscillation.</p>	<p>Recall the effect and the importance of minimising drift.</p>
3C2		<p>Recall that the frequency stability of an oscillator can be improved by rigid mechanical construction, screening the oscillator enclosure, a regulated DC supply and a buffer amplifier immediately after the oscillator circuit.</p> <p>Understand that a lack of stability (drift) may result in operation outside the amateur bands.</p> <p>Recall that most modern oscillators are digital synthesisers, which are very stable and are based on a crystal reference.</p>	
3C3		<p>Recall that digital signals can be used to generate audio and RF signals by Direct Digital Synthesis (DDS).</p> <p>Recall the meaning of DDS.</p> <p>Recall that a Direct Digital Synthesiser generates audio and RF signals from pre-set digital values held in a memory, or Lookup Table.</p>	<p>Recall the block diagram of a Phase Locked Loop (PLL) frequency synthesiser and the functions of the stages i.e. oscillator, fixed divider, phase comparator (detector), Low Pass Filter (LPF), voltage-controlled oscillator and programmable divider.</p> <p>Recall how sinusoidal waves may be produced by direct digital synthesis and the block diagram of a simple synthesiser.</p> <p>Recall that increasing the number of bits in the synthesiser will increase the purity of the signal.</p> <p>Recall the function of the Clock, Lookup Table, DAC and LPF in a DDS block diagram.</p>

Part 2 – The Syllabus

	Frequency multipliers		
3D1			Understand that frequency multipliers use harmonics to generate frequencies above an oscillator's fundamental frequency (e.g. in a microwave transmitter).
	Microphone amplifiers and modulators		
3E1	Recall that the microphone amplifier amplifies the signal from the microphone to the level required to drive the modulator and limits the audio frequencies to those required for communication. Recall the need to ensure that the microphone gain control (where fitted) is correctly adjusted.	Recall that a Balanced Modulator is used to produce two sidebands whilst suppressing the carrier.	Understand the operation of AM, SSB and FM modulators. Calculate the bandwidth of such transmissions.
3E2		Understand that an SSB filter is a Band Pass Filter that will only allow one sideband to pass to the Power Amplifier. Recall that in an analogue transmitter, SSB filters are normally constructed from a number of quartz crystals or other resonators.	Identify typical sideband filter circuits and calculate relevant frequencies.
3E3		Recall that a variable capacitance diode can be used in an oscillator to produce frequency modulation (FM).	
	RF power amplifiers		
3F1	Recall that the RF power amplifier stage increases the power of the modulated RF signal to the final output level.	Understand the concept of the efficiency of an amplifier stage and estimate expected RF output power for a given DC input power, given the stage's efficiency.	

Part 2 – The Syllabus

<p>3F2</p>			<p>Understand the need for linear amplification and identify which forms of modulation require a linear amplifier.</p> <p>Identify simple RF transmitter PA circuits.</p> <p>Understand the meaning of linearity as applied to a circuit or amplifier.</p> <p>Understand how distortion of a single frequency signal can produce harmonics of that frequency.</p> <p>Understand how distortion of two (or more) frequencies can produce harmonics and intermodulation products of the input frequencies.</p>
<p>3F3</p>	<p>Recall that the RF power amplifier output must be connected to a correctly matched load to work properly and that use of the wrong antenna can result in damage to the transmitter.</p>		<p>Recall the function of the main components of a PA circuit, i.e. collector load, bias, input circuit, output filter and matching.</p>
<p>3F4</p>			<p>Understand the implications for PA rating of different types of modulation and the effects of speech processing, with particular regard to peak to average power ratios.</p>
<p>3F5</p>			<p>Recall the function of automatic level control within the power amplifier circuit and when using an external power amplifier.</p> <p>Recall the function and use of a manual RF power control.</p>

Part 2 – The Syllabus

	Transmitter interference		
3G1	<p>Recall that excessive amplitude modulation causes distorted output and interference to adjacent channels.</p> <p>Recall that excessive frequency deviation will cause interference to adjacent channels.</p>		<p>Understand that over-modulation distorts the modulating signal resulting in harmonics of the audio which causes excessive transmitted bandwidth.</p>
3G2		<p>Recall that oscillators, mixers and amplifiers can produce harmonics which are multiples of the fundamental frequency.</p> <p>Recall that harmonics can cause interference to other amateur bands and other radio users.</p>	<p>Understand that over-drive of the RF power amplifier can also result in excessive transmitted bandwidth.</p> <p>Understand the need to drive external power amplifiers with the minimum power required for full output and how overdriving may cause harmonics and/or spurious intermodulation products.</p>
3G3		<p>Recall that a filter is a device that blocks some frequencies and passes others.</p> <p>Understand the effects of low-pass, bandpass and high-pass filters.</p> <p>Understand that a low-pass filter, a band-pass filter and a band stop (notch) filter can minimise the radiation of harmonics.</p> <p>Recall that RF power amplifiers can produce harmonics of the wanted signals and that suitable filtering is required to avoid harmonic radiation.</p>	<p>Understand ways to avoid generating harmonics e.g. use of push-pull amplifiers and avoiding high drive levels.</p> <p>Recall that transmitters may radiate unwanted mixer products and identify suitable remedies.</p> <p>Understand the use of low pass, band pass and band stop (notch) filters in minimising the radiation of unwanted harmonics and mixer products.</p>

Part 2 – The Syllabus

3G4		<p>Understand that too fast a rise and fall time of the transmitted RF envelope of a CW transmitter may cause excessive bandwidth (key clicks) and that this can be minimised by suitable filters in the keying stage.</p> <p>Recognise a diagrammatic representation of rise and fall time.</p>	<p>Recall that unwanted emissions may be caused by parasitic oscillation and/or self-oscillation and identify suitable remedies.</p>
3G5		<p>Recall the cause and effect of 'chirp' and identify suitable remedies.</p>	<p>Understand how frequency synthesisers may not produce the intended frequency.</p> <p>Identify appropriate measures to prevent off-frequency transmissions.</p>
	<p>Receiver concepts</p>		
3H1	<p>Recall that the function of a radio receiver is to recover information sent from one place to another using electromagnetic radiation/wireless technology.</p> <p>Recall that the process of recovering information from a modulated radio frequency signal is known as demodulation.</p>		
3H2	<p>Identify the items in a simple receiver block diagram and recall their order of interconnection: Antenna, feeder, wanted signal selection and RF amplification, demodulation/detection, audio amplification and loudspeaker or headphones.</p> <p><i>Note: See table 2.</i></p>	<p>Understand the block diagrams of the crystal diode receiver, and direct conversion receiver.</p> <p>Understand the functions of the RF amplifier, demodulator (detector), and audio amplifier as used in an analogue receiver.</p>	

Part 2 – The Syllabus

3H3		<p>Recall that a receiver's ability to detect weak signals is known as its sensitivity.</p> <p>Recall that very strong signals can overload a receiver and cause distortion to the audio output.</p>	<p>Understand that overloading a receiver causes intermodulation products and that those close to or within the wanted signal bandwidth limit the ability of the receiver to detect weak signals.</p> <p>Recall that the dynamic range of a receiver is the difference between the minimum discernible signal and the maximum signal without overload.</p> <p>Recall that dynamic range is expressed in decibels.</p>
3H4		<p>Recall that a receiver's ability to reject frequencies outside the wanted signal bandwidth is known as its selectivity.</p> <p>Understand the limitations of tuned circuits in selecting wanted frequencies and the effect of the Q factor of tuned circuits.</p> <p><i>See also Section 2H4.</i></p>	
	Superheterodyne concepts		
3I1		<p>Understand the need for and advantages of the superheterodyne architecture.</p> <p><i>Note: A diagram of the Single Conversion Superhet diagram is provided in section 4.</i></p>	<p>Understand the block diagram of superheterodyne and double superheterodyne receivers and the functions of each block.</p>
3I2		<p>Recall that the intermediate frequency is the sum of or difference between the RF and local oscillator frequencies and is produced by a mixer.</p>	<p>Understand the function of a mixer, the generation of the Intermediate Frequency (IF) and other mixer products.</p>

Part 2 – The Syllabus

313		<p>Recall that a superheterodyne receiver uses a fixed IF stage to enable good selectivity and that mixing ahead of the IF enables multi-band reception.</p> <p>Understand that tuned circuits in RF and IF amplifiers select the wanted signal.</p> <p>Identify the tuned circuits in the circuit of an IF amplifier.</p>	<p>Understand the advantages and disadvantages of high and low intermediate frequencies and the rationale for the double and triple superhet.</p> <p>Understand that for given RF and IF frequencies, there is a choice of two possible local oscillator (LO) frequencies.</p> <p>Understand the reasons for the choice and calculate the frequencies.</p> <p>Understand the origin of the image frequency and calculate the frequency from given parameters.</p>
314			<p>Understand the operation of an IF amplifier and the IF transformer.</p> <p>Understand the concept of two LC tuned circuits utilising transformer coupling.</p> <p>Identify critical and over-coupled response curves.</p> <p>Understand how the gain of an IF amplifier can be varied, how this may cause distortion and how the effects of the distortion are avoided.</p>
315			<p>Recall the source and effects of phase noise.</p> <p>Recall the unit of measurement is dBc/Hz.</p>

Part 2 – The Syllabus

	RF amplifiers and external pre-amplifiers		
3J1			<p>Recall the operation of the RF amplifier.</p> <p>Understand that external RF preamplifiers do not always improve overall performance and will reduce the dynamic range.</p> <p>Understand why, at HF, this loss can be as much as the gain of the preamp but that at VHF and above a low noise pre-amp is beneficial.</p> <p>Understand why most benefit is gained by locating the pre-amp at the antenna.</p>
	Demodulation		
3K1	<p>Recall that the detector/demodulator stage recovers the original information from the modulated signal.</p> <p>Recall that the audio amplifier ensures the recovered modulation is strong enough to drive headphones or a loudspeaker.</p>	<p>Understand how a diode detector will recover the audio from amplitude modulated signals.</p> <p>Understand that to generate the audio from CW signals a beat frequency oscillator (BFO) is used; for the recovery of single sideband audio a carrier insertion oscillator (CIO) and product detector are used and for the recovery of FM audio a discriminator is used.</p> <p>Identify the waveforms produced in a diode AM detector.</p>	<p>Understand the operation of basic analogue AM, CW, SSB and FM demodulator circuits and the function of the limiter for FM.</p>

Part 2 – The Syllabus

	Automatic gain control (AGC)		
3L1		<p>Understand that the automatic gain control (AGC) of a receiver operates by sensing the strength of the received signals at the detector and adjusting the gain of the IF and sometimes the RF amplifiers to keep the audio output level fairly constant.</p> <p>Recall that the AGC signal can also drive a signal strength meter (S-meter).</p>	<p>Understand the source and use of an AGC voltage.</p> <p>Recall that the speed of the AGC response can be adjusted on both attack and decay.</p>
	SDR transmitters and receivers		
3M1	<p>Recall that the SDR receiver takes in all electromagnetic signals from the antenna and digitises this input for processing in software.</p> <p>Recall that a mathematical operation enables all the signals to be sifted into separate frequency components.</p> <p>Recall that the required signal is selected using a filter defined in software.</p> <p>Recall that demodulation is carried out in software.</p> <p>Recall that Software Defined Radio (SDR) receivers convert incoming signals to digital format and then perform filtering and demodulation on the signal using software and that SDR transmitters generate modulated radio signals using software.</p>	<p>Recall that SDR software uses a mathematical function called a Fourier transform which sifts the composite signal into its constituent independent frequencies for processing.</p> <p>Recall that this can also be used to provide a spectrum or waterfall display.</p> <p>Recall that digital filters can be much more selective than analogue filters.</p>	<p>Recall that analogue and digital signals are transmitted by some form of amplitude and/or frequency/phase modulation.</p> <p>Recall that amplitude and frequency/phase modulation can be portrayed on a phasor diagram.</p> <p>Understand that to fully capture the information contained in the amplitude and phase of the signal that the position of the phasors must be resolved as the values on two axes at right angles.</p>

Part 2 – The Syllabus

3M2		<p>Recall the meaning of the time domain and the frequency domain.</p> <p>Understand how signals in the time domain may also be viewed in the frequency domain.</p> <p>Identify for some simple harmonic waves, the spectrum obtained using the Fourier transform. <i>(Waves composed of one and two Harmonics will be examined).</i></p>	<p>Recall that mixing the RF or IF signal with two local oscillator signals 90 degrees different in phase will produce an in-phase (I) and quadrature (Q) component which can be digitised allowing all forms of modulation to be demodulated entirely by mathematical processes in a PC or using dedicated hardware.</p> <p>Recall that this technique is the basis of SDR (software defined radio) receivers.</p> <p>Recall that these techniques can also be used to create complex modulations for use in transmitters.</p> <p>Recall that if sampling is carried out directly on the RF signal the extraction of I and Q components and subsequent demodulation may be carried out entirely by mathematical processes.</p>
3M3		<p>Recall the different elements that make up the functions of an SDR (block diagram).</p>	
	Transceivers		
3N1			<p>Understand that transceivers normally share oscillators between the transmitter and receiver circuits; and they may use common IF filters to limit both the transmitter and receiver bandwidths and that they also use common changeover circuits.</p> <p>Recall the function and use of the RIT control.</p>

Part 2 – The Syllabus

3N2			<p>Understand that using a transverter enables operation on frequency bands not covered by the primary transceiver equipment.</p> <p>Calculate appropriate frequencies used in transverter operation.</p> <p>Recall that transverters generally require low power drive.</p> <p>Understand the need for extra care to avoid transmitting out of band when using a transverter.</p> <p>Recall that transverters require the correct interfacing with the primary equipment to control sequencing and prevent hot switching.</p> <p>Understand the techniques of RF sensing and PTT (push-to-talk) transmit receive switching.</p>
------------	--	--	--

Part 2 – The Syllabus

	Section 4 – Feeders and antennas		
	Feeders		
4A1	<p>Recall the correct cable types to use for RF signals and that coaxial cable is most widely used because of its screening properties.</p> <p>Identify Twin Feeder & Coaxial as types of feeder.</p> <p>Understand that twin feeder is balanced having equal and opposite signals in the two wires.</p> <p>Understand that coaxial feeder is unbalanced with the signal on the centre conductor surrounded by a screen.</p>	<p>Understand the equal and opposite currents flowing in a balanced feeder cause equal and opposite fields around the two conductors.</p> <p>Understand that these fields cancel out, but that nearby objects can cause an imbalance that makes the feeder radiate RF energy.</p> <p>Recall that a rectangular waveguide must have its larger dimension greater than $\lambda/2$ for the signal to travel.</p>	
4A2	<p>Recall that some RF energy is converted to heat in feeders so they exhibit loss.</p> <p>Recall that feeders cause loss of signal strength on both transmit and receive; the longer the cable, the greater the loss.</p> <p>Recall that feeder loss increases with frequency and that low loss feeders (lowest dB per unit length) should be used at VHF and UHF.</p>	<p>Recall that twin feeder usually has lower loss than coaxial cable.</p> <p>Recall that loss is measured in dB.</p> <p>Understand the relationship between RF output power, feeder loss and power delivered to the antenna.</p> <p>Calculate the unknown quantity given the other two.</p> <p><i>Feeder loss will be in multiples of 3dB and 10dB.</i></p>	

Part 2 – The Syllabus

4A3		<p>Recall that feeders have a characteristic impedance which depends upon the diameter and spacing of the conductors.</p> <p>Recall that this impedance determines the ratio of the RF RMS potential difference to the RF, RMS current in a correctly terminated feeder.</p> <p>Recall that for amateur use 50Ω coaxial feeder is normally used; that coaxial cable for TV and satellite receivers has a different impedance of 75Ω.</p> <p>Recall that balanced feeder is commonly available from 75Ω to 600Ω.</p> <p>Recall that correctly terminated means correctly connected with a resistive load equal to the cable characteristic impedance.</p>	<p>Understand that the velocity factor of a feeder is the ratio of the velocity of radio waves in the feeder to that in free space and that the velocity factor is always less than unity.</p> <p>Recall that the velocity factor for coaxial feeder with a solid polythene dielectric is approximately 0.67 or 2/3.</p> <p>Perform calculations involving velocity factor, physical length, electrical length and frequency.</p>
	Baluns		
4B1	Recall the difference between balanced and unbalanced antennas and that a balun should be used when feeding a dipole with coaxial cable (which is unbalanced).	Recall the construction and use of choke type baluns.	<p>Recall the construction and use of transformer, sleeve and choke type baluns.</p> <p>Identify the circuits of 1:1 and 4:1 transformer baluns.</p>
	Antenna concepts		
4C1	Recall that the purpose of an antenna is to convert electrical signals into radio waves (and vice-versa) and that these are polarised according to the orientation of the antenna, e.g. a horizontally oriented antenna will radiate horizontally polarised waves.		

Part 2 – The Syllabus

<p>4C2</p>	<p>Understand the concept of an antenna radiation pattern.</p> <p>Identify the polar diagrams for the half wave dipole and Yagi antennas and identify the directions of maximum and minimum radiation.</p> <p>Understand that half-wave dipoles (mounted vertically), $\lambda/4$ (quarter wavelength) ground planes and $5/8 \lambda$ antennas are omni-directional.</p> <p><i>Note: only dipole and Yagi antennas will be examined for radiation pattern.</i></p>	<p>Understand the front-to-back ratio of an antenna.</p> <p>Understand the beam width of an antenna.</p> <p>Understand that radiation patterns exist in three dimensions.</p>	
<p>4C3</p>	<p>Understand that antenna gain is due to its ability to focus radiation in a particular direction.</p> <p>Recall that a Yagi antenna typically has a higher gain because of its improved focussing ability.</p> <p>Recall the gain of an antenna is normally expressed relative to a half-wave dipole and measured in dB (Higher dB value is a higher gain).</p> <p>Recall that the directional power is expressed as Effective Radiated Power (ERP) and that the apparent power increase is known as gain.</p> <p>Recall that ERP is calculated by multiplying the power applied to the antenna feed point by the gain of the antenna.</p> <p>Calculate ERP given antenna input power and antenna gain.</p> <p><i>Note: dB conversion table (3, 6 & 10) will be provided.</i></p>		

Part 2 – The Syllabus

<p>4C4</p>	<p>Recall that antenna gain can also be expressed relative to a theoretical antenna that radiates equally in all directions and this is shown as EIRP, Effective Isotropic Radiated Power.</p> <p>Recall that 10W EIRP is equivalent to 6.1W ERP.</p>	<p>Recall that an isotropic radiator is a theoretical antenna that radiates equally in all directions.</p> <p>Recall the Effective Isotropic Radiated Power (EIRP) is based on an isotropic antenna reference rather than a dipole and is expressed in dBi.</p> <p>Recall that a half-wave dipole has a gain, in its optimum direction, of 2.15dBi</p>	
<p>4C5</p>	<p>Recall that VHF and UHF signals will normally be received most effectively when the transmitter and the receiver have the same antenna polarisation and that this is less important at HF because the polarisation may change during ionospheric reflection.</p>	<p>Recall that the angle at which the radio wave leaves the antenna is known as the angle of radiation and that longer distances normally requires a lower angle of radiation.</p> <p>Recall the effect of the ground on the angle of radiation.</p>	
<p>4C6</p>	<p>Recall that the connection point of the feeder to the antenna is called the feed point.</p> <p>Recall that at the design frequency the feed point has an impedance that should match the impedance of the feeder and the transmitter.</p> <p>Recall that the feed point impedance of an antenna is related to the dimensions of the antenna and the wavelength of the applied signal.</p> <p>Recall that if the feed point impedance of the antenna does not match that of the feeder, energy will be reflected back down the feeder; the proportion reflected depending upon the degree of mismatch.</p>	<p>Recall that the current flowing into an antenna is related to the feed point impedance and the potential difference of the applied signal.</p> <p>Recall that an antenna will only present the correct feed point impedance when fed with the frequency for which it is designed.</p> <p>Recall that a centre fed half-wave dipole has a feed point impedance of 73Ω in free space and that under practical conditions (e.g. due to ground proximity effects) this will be approximately 50Ω when used at its designed frequency.</p>	

Part 2 – The Syllabus

	Types of antenna		
4D1	<p>Identify the half-wave dipole, $\lambda/4$ (quarter wavelength) ground plane, Yagi, end-fed wire and $5/8 \lambda$ (five eighths wavelength) antennas.</p> <p>Understand that the sizes of HF and VHF antennas are different because they are related to wavelength, though they operate on the same basic principles.</p> <p>Understand that the $\lambda/2$ (half wavelength) dipole has a physical length approximately equal to a half wavelength of the correct signal.</p>	<p>Recall that a three-element Yagi has a half-wave driven element, a reflector that is slightly longer than the driven element and a director that is slightly shorter than the driven element.</p> <p>Recall that Yagi antennas may have more than one director.</p>	<p>Recall the equation for calculating wavelengths and apply an end factor correction when calculating the approximate physical lengths of simple dipoles and end fed antennas.</p>
4D2		<p>Recall that an antenna trap is a parallel tuned circuit and understand how it enables a single antenna to be resonant and have an acceptable feed-point impedance on more than one frequency.</p> <p>Recall that this technique may be extended to multielement antennas such as Yagis.</p>	<p>Recall the current and voltage distribution on the centre fed dipole and $\lambda/4$ ground plane antennas.</p> <p>Recall the feed point impedances of centre fed half-wave dipoles, quarter-wave and loaded $5/8\lambda$ verticals, folded dipoles, full-wave loops and end feed $\lambda/4$ and $\lambda/2$ antennas.</p> <p>Recall the effect of passive antenna elements on feed point impedance and the use of folded dipoles in Yagi antennas.</p>

Part 2 – The Syllabus

	Standing waves		
4E1	<p>Recall that the antenna system must be suitable for the frequency of the transmitted signal.</p> <p>Recall that if an antenna is not correctly designed for the frequency it will not match the transmitter and will not work effectively.</p> <p>Recall that if the antenna does not match the feeder some power from the transmitter will be reflected back towards the transmitter causing standing waves.</p>	<p>Understand that the signal reflected back down the feeder will combine with the waves travelling up the feeder from the transmitter leading to the formation of standing waves.</p> <p>Recall that both forward and reflected signals are subjected to feeder loss.</p> <p>Recall that the reflected signal will change the input impedance of the feeder so that it is no longer the characteristic impedance and the feeder will not then present the correct impedance to the transmitter.</p>	<p>Understand that the standing wave ratio (SWR) is a measure of the signal travelling back down the feeder expressed in terms of the standing waves caused by the reflected signal voltage (or current).</p>
4E2	<p>Recall that an SWR meter shows whether an antenna presents the correct match to the transmitter and is reflecting minimum power back to the transmitter.</p> <p>Recall that a high SWR, measured at the transmitter, is an indication of a fault in the antenna or feeder and not the transmitter.</p> <p>Recall that the transmitter may be damaged in the presence of a high SWR much greater than 2:1.</p>		<p>Recall that return loss is the ratio of the forward signal power to the return signal power; normally expressed in dB.</p> <p>Understand that a low SWR equates to a high return loss and a high SWR equates to a low return loss.</p>
4E3			<p>Understand that the loss in the feeder will reduce the SWR and increase the return loss as measured at the transmitter and that the SWR at the antenna is unaffected.</p> <p>Recall that Return Loss at transmitter = Return Loss at antenna + 2x (feeder loss).</p>

Part 2 – The Syllabus

	Antenna matching units		
4F1	Recall that where an antenna has not been designed for the frequency being used, the feed resistance will change resulting in a mismatch and that an Antenna Matching Unit (AMU), also sometimes referred to as an ATU, can correct the mismatch and is used to ensure that the transmitter can supply energy to the antenna without damage to the transmitter.	Recall that a transmitter is designed to transfer energy into a specific impedance. Understand that an antenna matching unit (AMU) can change the impedance presented to the transmitter and that an AMU does not tune the feeder or the antenna to resonance. Understand that if the AMU is located at the transmitter, it will have no effect on the actual SWR on the feeder between the AMU and antenna.	Understand that Antenna Matching Units (AMUs) can cancel reactive components of the antenna system feed point impedance (before or after the feeder) and can transform impedances to an acceptable resistive value. Identify typical AMU circuits i.e. T, Pi and L circuits.
4F2			Understand that a quarter-wave length of feeder can be used as an impedance transformer. Apply simple examples of the formula $Z_o^2 = Z_{in} \times Z_{out}$
	Plugs and Sockets		
4G1	Recall that the plugs and sockets for RF should be of the correct type and that the braid of coaxial cable must be correctly connected to minimise RF signals getting into or out of the cable. Identify BNC, N, SMA and PL259 plugs as shown in Table 2.	Recall that in a correctly connected and terminated coaxial cable the RF field only exists within the cable and is not affected by objects outside the cable. <i>Note that correctly connected means screen and inner conductor continuity through any plug and socket.</i>	

Part 2 – The Syllabus

	Section 5 – Propagation		
	Radio propagation: key concepts		
5A1	<p>Recall that radio waves normally travel in straight lines.</p> <p>Recall that they can be refracted, diffracted and reflected.</p> <p>Recall that radio waves get weaker as they spread out.</p>		<p>Recall that under free space conditions e-m waves spread out according to an inverse square law of power flux density and that the electric field strength, measured in volts/metre, drops linearly with distance.</p> <p><i>Note: Numerical calculations required at item 6E1 only</i></p>
5A2	<p>Recall that VHF and UHF signals normally pass through the ionosphere and at these frequencies propagation is within the troposphere situated below the ionosphere.</p>	<p>Understand the meaning of ground wave, tropospheric (space) wave, sky wave, skip distance and skip zone (dead zone).</p> <p>Understand why the ground wave has a limited range due to absorption of energy in the ground and that the loss increases with increasing frequency.</p>	
5A3		<p>Recall that electromagnetic radiation comprises both an electrical field and a magnetic field.</p> <p>Recall that the two fields are always at right angles to each other and that the direction of propagation is at right-angles to both fields.</p> <p>Recall that it is the plane of polarisation of the electric field that defines the polarisation of the electromagnetic wave.</p>	<p>Recall that an e-m wave comprises E and H fields in phase, at right angles and at right angles to the direction of travel and the power flux density (watts / Metre squared) is given by the product of E and H.</p> <p>Recall that in circular polarisation, the polarisation of the wave rotates as it propagates, with either a right-handed (clockwise from behind) or left-handed polarisation.</p> <p>Recall that this is often used for satellite communication where the orientation of the satellite is indeterminate.</p> <p>Recall that the transmit and receive antennas should have the same polarisation.</p>

Part 2 – The Syllabus

	Ionosphere		
5B1	<p>Recall that the ionosphere comprises layers of ionised gases at heights between 70 and 400km above the earth.</p> <p>Understand that ionisation is caused mainly by ultraviolet rays from the sun.</p>	<p>Understand that the ionosphere comprises layers of ionised gases and that the ionisation is caused by solar emissions including ultraviolet radiation and charged solar particles.</p> <p>Recall the ionospheric layers (D, E, F1 and F2) and approximate heights.</p>	<p>Understand the effects of Solar flares and sun spots on propagation.</p>
5B2	<p>Recall that on HF most communication relies on the waves being refracted in the ionosphere.</p> <p>Recall that HF can provide world-wide propagation depending on how well the ionosphere refracts the waves back to the earth.</p> <p>Recall that this varies with frequency, time of day, season and solar activity.</p> <p>Recall that a band is said to be 'open' when it supports skywave propagation.</p>	<p>Recall that the level of ionisation changes with the time of day, the time of year, and according to the, approximately, 11-year sunspot cycle.</p> <p>Understand that the sunspot number is an indicator of solar activity and that more sunspots give better HF propagation as a result of increased ionisation.</p> <p>Recall that the highest frequency that will be refracted over a given path is known as the maximum usable frequency (MUF).</p>	<p>Recall that the highest frequency that will be refracted back to the transmitter is known as the Critical Frequency of Vertical Incidence (critical frequency).</p> <p>Recall that the maximum usable frequency (MUF) will be higher than the critical frequency.</p> <p>Recall, in general terms how the MUF varies over the 24 hour cycle and the variation in MUF from summer to winter.</p>

Part 2 – The Syllabus

<p>5B3</p>		<p>Recall that the F2 layer provides the furthest refractions for HF signals (about 4000km) and that the F layers combine at night.</p> <p>Recall that multiple hops permit worldwide propagation.</p> <p>Understand how fading occurs and its effect on the received signal.</p> <p>Recall that Short Path ionospheric propagation of HF signals is the most direct route around the earth.</p> <p>Recall that Long Path ionospheric propagation is where HF signals are received via the opposite route around the earth to the Short Path.</p>	<p>Recall that propagation where the signals are reflected vertically back from the ionosphere is known as Near Vertical Incidence Sky wave (NVIS).</p> <p>Recall that NVIS is a technique employed on some low frequency bands (e.g. 5MHz) to make contacts over relatively short distances.</p>
<p>5B4</p>		<p>Recall that the D layer tends to absorb the lower radio frequencies during daylight hours and that it tends to disappear at night.</p> <p>Recall that the lowest frequency that can pass through the D-layer without significant absorption is the lowest usable frequency (LUF).</p> <p>Understand that if the D-layer absorption (LUF) occurs at frequencies higher than the MUF then no ionospheric propagation can occur.</p>	<p>Recall that the ionosphere can change the polarisation of a radio wave.</p>
<p>5B5</p>		<p>Recall that in addition to VHF, waves in the in the 24 MHz and 28 MHz upper HF band can also occasionally be significantly increased by refraction from highly ionised areas in the E layer (Sporadic E).</p> <p>Recall that the height of the E layer will support a single hop of up to about 2000km and that multi-hop propagation can occur.</p>	

Part 2 – The Syllabus

	VHF and above		
5C1	<p>Recall that hills cause radio shadows and that signals become weaker as they penetrate buildings.</p> <p>Recall that at VHF/UHF, range decreases as frequency increases and that in general VHF/UHF waves have a range not much beyond line of sight.</p> <p>Recall that sporadic E and atmospheric ducting can increase the range of VHF and UHF signals.</p>		
5C2	<p>Recall that falling snow, hailstones and heavy rain can attenuate signals at UHF and above.</p>		

Part 2 – The Syllabus

<p>5C3</p>	<p>Recall that the range achieved at VHF/UHF is dependent on antenna height, antenna gain, a clear path and transmitter power.</p> <p>Understand that higher antennas are preferable to higher power as they improve both transmit and receive performance.</p> <p>Recall that outdoor antennas will perform better than indoor antennas.</p>	<p>Recall that at VHF and above, multipath propagation can occur where signals are reflected off objects (such as a buildings or aircraft) and the reflected signal is received in addition to the direct, un-reflected, signal.</p>	<p>Recall that contacts at VHF and above can be made by reflecting signals off the lunar surface and that this is known as Earth-Moon-Earth (EME) propagation.</p> <p>Understand that as the moon is a poor reflector of radio frequency signals and is a long way from earth, EME contacts generally need high power and high gain antennas accurately pointed at the moon, and very sensitive, low noise receivers or the use of special low-signal strength modes to overcome the path loss.</p> <p>Recall that it is possible to make contacts on the VHF bands by reflecting signals off the ionised gases created during an Aurora and that this occurs at high Northerly and Southerly latitudes and that this is known as Auroral propagation.</p> <p>Recall that auroral ionised curtains form vertically in the ionosphere and that movement of these curtains cause rapid flutter on the signals.</p>
	<p>Other features</p>		
<p>5D1</p>			<p>Recall the Galactic Noise is random noise originating outside the earth's atmosphere.</p>
<p>5D2</p>			<p>Recall the factors affecting a link budget, transmitter power, feeder losses, antenna gains and path loss.</p> <p>Recall that path loss includes spreading loss and obstruction losses.</p>

Part 2 – The Syllabus

	Section 6 – Electro magnetic compatibility (EMC)		
	EMC concepts		
6A1	Recall that electromagnetic compatibility (EMC) is the avoidance of interference between various pieces of electronic equipment.	<p>Understand that all electronic equipment is capable of radiating and absorbing radio frequency energy.</p> <p>Recall that the basic principle of electromagnetic compatibility is that apparatus should be able to function satisfactorily in its electromagnetic environment and without causing undue electromagnetic disturbance to other apparatus in that environment.</p>	
6A2	Recall that the ability of any piece of electronic or radio equipment to function correctly in the presence of strong RF signals is known as immunity.	Recall that the immunity of a device can often be improved by screening and filtering power, signal and control leads.	Understand that the immunity of a device is affected by the nature of its installation and that poor installation of an otherwise good item of equipment can compromise its safe and compliant operation.
6A3	Recall that radio transmitters can cause interference to nearby electronic and radio equipment.	<p>Understand that transmitters in domestic environments may give rise to RF fields stronger than the agreed limits.</p> <p>Understand that transmitters in domestic environments are not normal situations and special measures may have to be taken.</p>	
6A4	Recall that radio receivers can also suffer from interference from local and other sources.	Understand that new electronic equipment should meet the British Standards Institute immunity requirements but that existing equipment and poorly installed equipment may not.	Recall that radio amateurs are not required to demonstrate compliance with EMC standards for equipment they put into service but remain responsible for complying with licence requirements regarding interference.

Part 2 – The Syllabus

	Sources of interference and their effects		
6B1	<p>Recall that the more power a station runs, the more likely it is to cause interference.</p> <p>Recall that some types of transmission are more likely to cause interference to TV, Radio and telephones than others.</p> <p>Recall that AM and SSB modes are the most likely to cause problems, FM and some of the HF data modes are least likely to cause problems.</p>	<p>Recall that speech transmissions, particularly AM and SSB may cause speech like sounds in analogue radio, audio systems and telephones.</p> <p>Recall that FM transmission is more likely to mute or reduce the volume of the wanted signals (audio or RF).</p>	<p>Recall that some imported or home constructed electronic equipment may not meet relevant EMC standards.</p> <p>Recall that items containing radio communication facilities such as cordless and mobile telephones and information technology communication equipment may produce sufficiently strong signals to cause short range interference but are otherwise generally satisfactory.</p> <p>Recall that imported devices and toys may not be compliant with the relevant regulations.</p>
6B2		<p>Recall non-radio sources of interference and their effects:</p> <ul style="list-style-type: none"> • Arcing thermostats • Vehicle ignition systems • Electric Motors • Computers and peripherals • Switch mode power supplies • Plasma TVs • Very high bit rate digital subscriber line (VDSL) equipment • LED lighting • Solar photovoltaic (PV) inverters <p>Recall that this gives rise to various buzzing sounds on analogue radio receivers which can correlate with the nature and use of the interference source e.g. bursts of undesirable sounds when a thermostat opens or closes.</p>	<p>Understand that Blocking (or desensitisation) is an effect in a radio receiver where a strong, constant level interfering signal e.g. FM either swamps the wanted signal or drives the affected circuits out of their normal operating range such that the received audio or data is severely attenuated or muted.</p> <p>Understand that Cross-modulation is an effect in a radio receiver where the interfering signal is varying in strength e.g. AM or SSB such that the modulation on the interfering signal is added to the modulation on the wanted signal such that both may be heard with varying clarity.</p>

Part 2 – The Syllabus

6B3		Recall that interference to Digital Audio Broadcasting (DAB) may cause loss of signal (muted audio) and to digital televisions may cause the picture to freeze, appear to pixelate; that is break up into larger squares, become jerky or disappear.	Recall that passive intermodulation products can be caused by corrosion in any metallic junctions in metalwork, including transmitting and receiving antennas, supports and guttering.
	Routes of entry		
6C1	Recall that interference occurs through local radio transmissions being conveyed to the affected equipment through pick up in house wiring, TV antenna down-leads, telephone wiring etc and particularly at VHF/UHF by direct pick-up in the internal circuits of the affected equipment.	Recall that direct pick up in affected devices tends to be independent of a specific frequency within a band although differences may be noticed between different bands. Recall that direct pickup is especially an issue in the VHF/UHF bands.	Recall that amateur transmissions can enter audio stages via long speaker leads or other interconnections. Understand that any semiconductor or diode junction within an electronic device can rectify unwanted RF.
6C2		Understand that some masthead and down lead TV amplifiers are broadband, amplifying a wide range of frequencies, including amateur frequencies. Understand that this can result in overloading of the amplifier and/or the TV input.	Understand that many TV mast-head amplifiers are wide band devices and can suffer from cross-modulation and overload causing intermodulation, blocking and may also overload the TV.

Part 2 – The Syllabus

6C3			<p>Understand that amateur transmissions can be picked up by the intermediate frequency stages of TV and radio receivers.</p> <p>Understand the potential for image frequency interference to analogue and digital radio.</p> <p>Understand that television receivers and most broadcast radio receivers employ superheterodyne circuits and recall some typical frequencies used in radio and television receivers:</p> <ul style="list-style-type: none">• Medium Wave radio broadcast 526 - 1606kHz• VHF FM radio broadcast 87.5 - 108MHz• VHF DAB radio broadcast 174 - 230MHz• TV broadcast 470 - 694MHz• Radio IFs typically 455 - 500kHz and 10.7MHz. <p><i>Note: Current design digital TV receivers use a variety of Intermediate frequencies between 4 and 39MHz.</i></p>
------------	--	--	---

Part 2 – The Syllabus

	Filtering and remedial measures		
6D1	<p>Recall that the immunity of most types of equipment can be increased by fitting suitable external chokes and filters in mains or antenna leads.</p> <p>Recall that the filters should be fitted as close to the affected device as possible.</p>	<p>Understand that filters can be fitted in the leads from the power supply to the transmitter to help minimise RF energy entering the mains wiring.</p> <p>Recall the use of ferrite ring filters for minimising unwanted RF on antenna downleads and mains leads to affected equipment.</p> <p>Recall and understand the use of high-pass or lowpass filters to reduce the level of HF and VHF amateur transmissions into other electronic equipment.</p> <p>Understand the use of mains filters to reduce RF, electric motor and thermostat interference to TV, radio and audio systems.</p>	<p>Understand the use of high, low, band pass and band stop (notch) filters of L, T and π configuration including coaxial stubs as notch filters or traps, in improving the immunity of affected devices.</p> <p>Recall the use of ferrite beads or rings in internal and external filtering.</p>
6D2		<p>Understand the meanings of common mode and differential mode currents and signals.</p> <p>Understand how a ferrite ring or choke can be used to attenuate common mode signals in twin wires and braid currents on coaxial cables.</p>	<p>Understand the construction and use of a typical mains filter.</p> <p>Identify a typical circuit of a braid breaking filter and a combined high pass/ braid breaking filter.</p> <p>Understand their use.</p> <p>Understand why a ferrite ring will attenuate common-mode currents without affecting the differential-mode wanted signal.</p>
6D3		<p>Recall how to use a suitable general coverage receiver to check for spurious and harmonic emissions from the station.</p>	

Part 2 – The Syllabus

<p>6D4</p>	<p>Recall that transmitting into a dummy load is a good test for any unwanted RF being conducted out of the transmitter along its power supply leads and any connected interface leads and into the mains.</p> <p>Recall that a dummy load is a screened resistor of the correct value and a suitable power rating connected instead of an antenna to allow the transmitter to be operated without radiating a signal.</p>	<p>Understand the use of a dummy load in fault finding.</p> <p>Recall that the resistor(s) used in a dummy load must be non-reactive and of a suitable power rating.</p> <p>Recall how to use a dummy load to check if interference is being caused by a radiated signal or leakage into the mains or other wiring.</p>	
	<p>Station design and antenna placement/general principles</p>		
<p>6E1</p>	<p>Recall that EMC problems can be minimised by siting antennas as far away from houses as possible, as high as possible, and using balanced antennas at HF.</p> <p>Recall that, at HF, horizontal dipoles are less likely to be a problem and that end-fed wires can present significant EMC problems.</p> <p>Recall that information on avoiding interference can be obtained from the RSGB's EMC team and experienced local amateur radio club members.</p>	<p>Recall how to interconnect the transmitter, microphone, power supply, SWR meter and band or low pass filters, using appropriate cables, to minimise EMC problems.</p>	<p>Recall that reducing field strength to the minimum required for effective communication is good radio housekeeping.</p> <p>Apply the formula for the field strength surrounding an antenna given the ERP and distance from it.</p>
<p>6E2</p>	<p>Recall that the function of the RF earth connection in an amateur station is to provide a path to ground to minimise RF currents entering the mains earth system and causing interference to other electronic equipment.</p>	<p>Recall what constitutes a good RF earth, its purpose and use.</p>	<p>Understand good RF grounding and bonding techniques.</p> <p>Understand the effects of inadequate RF grounding and bonding.</p>

Part 2 – The Syllabus

6E3		Understand that siting a transmitting antenna close to mains wiring, TV or radio antennas and down-leads is a potential problem exacerbated by the use of a loft or indoor transmitting antenna.	Recall that balanced antenna systems tend to cause fewer EMC problems than unbalanced antennas. Recall that balanced and unbalanced feeders should leave the antenna at right-angles to minimise coupling.
	Station design and antenna placement/mobile installations		
6F1	Recall that it is the vehicle owner's responsibility to ensure that any radio installation is compatible with the vehicles electrical and management systems and does not affect vehicle safety. Recall that the fact of the installation may have to be disclosed to the vehicle insurers. Recall that professional advice should be sought for all vehicle installations.		Recall that advice on mobile installations is the Federation of Communication Services UK Code of Practice for the installation of mobile radio and related ancillary equipment in land based vehicles.
6F2	Recall that any tests following mobile radio equipment installation should be done with the vehicle stationary with all vehicle electronic systems operating before any on-road tests are carried out.	Recall that when routing RF cables and mobile radio DC power leads within vehicles they should not be routed in parallel with the vehicle wiring loom and they should not be run near electronic control units. Recall that radio frequency energy can cause interference to vehicle electronic circuits, including audio systems, navigation systems, remote locking, alarms and engine fuel management systems particularly when operating equipment with an RF output of 10W or more.	Understand how to minimise the likelihood of stray RF currents entering the vehicle wiring and electronics.

Part 2 – The Syllabus

6F3	Recall that vehicle ignition and battery charging systems can cause electrical interference to reception on mobile radio equipment.	Understand that mobile antenna location can affect the radiation field strength within the vehicle; e.g. wing or boot mounted antennas are likely to produce higher exposures than roof mounted antennas.	
	Social aspects and testing		
6G1	Recall that EMC problems have the potential for causing neighbour disputes. Recall that the RSGB produce EMC and Interference information leaflets. Recall that advice is available from the RSGB EMC Committee and recall the role Ofcom in dealing with cases of interference.		Recall the correct procedures for dealing with complaints of electromagnetic disturbance caused by amateur transmissions.
6G2	Understand that the station log will be of considerable assistance in dealing with complaints of interference, and that this is a good reason to keep a log of all transmissions. Understand the merits of both the amateur and the complainant keeping a log of the instances of interference. Understand the merit of conducting tests in cooperation with the complainant in instances of interference.		

Part 2 – The Syllabus

	Section 7 – Operating practices and procedures		
	Good operating practices and procedures		
7A1	Understand why one should listen on a frequency before calling and then ask if the frequency is in use.		Understand the reasons why some stations may use split Tx and Rx frequencies within a frequency band.
7A2	Recall how to make a CQ call in SSB and FM modes.		
7A3	Understand the need to move off the calling channel when on VHF/UHF once contact is established. Understand the meaning of Centre of Activity.	Recall common international call sign prefixes; EI (Eire), F (France), I (Italy), JA (Japan), PA (Netherlands), VE (Canada), VK (Australia), W (USA), ZL (New Zealand).	
7A4	Recall the meaning of the optional suffixes /A, /P, /M and /MM.		
7A5	Recall the phonetic alphabet.	Recall that there are awards available for achievements which include: working continents, countries, islands, prefixes, locator squares and that variations may include certain frequency bands or low power. Recall that amateur radio contests require the exchange of information such as signal report, serial number and location. Recall that contests often have sections for different bands, power levels and modes.	

Part 2 – The Syllabus

<p>7A6</p>	<p>Understand the advisability and common practice of keeping a log.</p> <p>Understand why UTC is used for logging time.</p> <p>Recall that a log should detail the following information: date, time, mode, call sign of station worked for QSL and contest purposes.</p>		
<p>7A7</p>	<p>Understand that the transmission of music and the use of offensive or threatening language whilst on the air are unacceptable in amateur radio.</p> <p>Understand how to respond to music or inappropriate language overheard or received from other stations.</p>		
<p>7A8</p>	<p>Recall the advisability to carry out tests to ensure that the station is not causing undue interference to other radio users.</p>		<p>Understand the need to conduct tests from time to time to ensure that the station is not causing Undue Interference to other radio users.</p>

Part 2 – The Syllabus

	Band plans		
7B1	<p>Recall why band plans are used.</p> <p>Identify items on a typical band plan (e.g. calling frequencies and recommended modes).</p> <p>Recall that narrow band modes are at the lower end of most bands.</p> <p>Recall that lower sideband operation normally occurs below 10MHz and upper sideband above 10MHz.</p> <p>Recall that transmissions on frequencies shown in the band plans for beacons should be avoided.</p> <p><i>Note: For the purposes of the examination narrow modes are CW and data.</i></p> <p><i>A copy of the relevant band plans will be available during the examination but may not be ones in current use.</i></p> <p><i>Reference Booklets containing examination band plans are available on the RSGB web site.</i></p>	<p>Recall that band plans are produced by the IARU.</p> <p>Recall that the band plans state that:</p> <ul style="list-style-type: none"> • no SSB operation should take place in the 10MHz (30m) band. • no contests shall be organised in the 5MHz (60m), 10MHz (30m), 18MHz (17m) and 24MHz (12m), bands. • transmissions on satellite frequencies should be avoided for terrestrial contacts. <p><i>Note: The 5MHz (60m) band is NOT available to Intermediate Licence holders.</i></p> <p><i>Questions on beacon and satellite frequencies will be limited to the 14MHz (20m) and 144MHz (2m) bands.</i></p> <p><i>A copy of the relevant band plans will be available during the examination but may not be ones in current use.</i></p> <p><i>Reference Booklets containing examination band plans are available on the RSGB web site.</i></p>	<p>Identify items on a typical band-plan (e.g. centre of activity, band width and recommended modes).</p> <p><i>Note: Questions will be limited to the 5MHz (60m) and 472kHz (600m) bands.</i></p> <p><i>A copy of the relevant band plans will be available during the examination but may not be ones in current use.</i></p> <p><i>Reference Booklets containing examination band plans are available on the RSGB web site.</i></p>

Part 2 – The Syllabus

<p>7B2</p>	<p>Recall that frequency bands are allocated for particular use, e.g. broadcasting, aeronautical, maritime and amateur.</p> <p>Recall the frequency bands for HF, VHF, and UHF radio signals.</p> <p>Recall that some amateur bands are shared with or adjacent to other spectrum users.</p> <p>Identify items on a provided chart of spectrum users.</p>		<p>Recall that band plans in other countries and IARU regions may not align with the UK band plan.</p>
	<p>Repeaters</p>		
<p>7C1</p>	<p>Recall that repeaters are mainly intended to extend the range of mobile stations.</p> <p>Recall why a frequency offset between transmit and receive is needed.</p> <p>Recall why a CTCSS tone is needed to access a repeater and why different repeaters may have different tones.</p> <p>Recall why repeaters may have a 'reset' tone and a time-out facility.</p> <p>Recall that simplex operation on repeater frequencies should not take place.</p> <p><i>Note: Questions may ask why particular facilities (such as frequency offset) exist, what operational issue they address or how they should be used to establish or maintain a contact.</i></p>		
<p>7C2</p>	<p>Recall that users of analogue FM and Digital Voice (DV) should first check that the channel is not in use by other modes.</p> <p>Recall that such checks are not 100% reliable.</p>		

Part 2 – The Syllabus

	Connecting input devices to transmitters		
7D1	Recall that connecting anything other than the supplied microphone to the transmitter requires correct operation of the PTT line and that the audio signal levels are correct.		
	Codes and abbreviations		
7E1		Recall the meaning and the reason for use of the Q codes: QRM, QRN, QRO, QRP, QRT, QSB, QSL, QSO, QSY, QTH.	
7E2	Recall the meaning of the RST code, the number of divisions of each of the three items, and their order of merit.		
	Digital interfaces		
7F1	Recall that there are Digital Voice (DV) and Digital Data (DD) modes available and that different systems may not be compatible. Recall that appropriate radio equipment is needed for each of these digital systems. Recall that DV radios may embed the call sign in the transmission and this will need to be adjusted if using borrowed equipment.		

Part 2 – The Syllabus

7F2		<p>Recall that several types of transmissions can be generated and received with the use of a personal computer and a suitable interface.</p> <p>Recall minimal distortion can be obtained by careful adjustments between the DAC interface and the transmitter.</p> <p>Recall other programs running on the PC that is handling the transmitter or receiver audio may cause interference e.g. warning beeps and alerts.</p>	
	Satellites		
7G1	<p>Recall that amateur satellites operate in allocated frequencies within the Amateur bands.</p> <p>Recall that terrestrial operation on satellite frequencies should not take place.</p>	<p>Recall that satellites orbit the Earth at heights above 250km and understand that most amateur satellites are moving in relation to the Earth and will only be above the horizon at certain times.</p>	
7G2		<p>Recall that the up-link and down-link frequencies are generally in different amateur bands and that details are published by amateur organisations.</p> <p>Recall that it is recognised as best practice that the transmitting station is able to receive both the up-link and down-link signals..</p>	
7G3		<p>Understand that amateur satellites can only be used when they are above the horizon at both the sending and receiving stations, and that the movement of the satellite will cause frequency variation, known as Doppler shift, on the received signal, which must be allowed for when selecting operating frequencies.</p>	

Part 2 – The Syllabus

7G4		Understand that satellites have a very limited power supply, derived from solar panels, and that excessive up-link power may result in wasteful and unfair use of the satellite's power.	
	CEPT and international		
7H1	Recall that other Administrations (foreign countries) do not routinely recognise the Foundation Licence.	Recall that other Administrations (foreign countries) do not routinely recognise the Intermediate Licence.	<p>Understand the requirements for operation by individual UK Licensees abroad under the CEPT Recommendation T/R 61-01 and T/R 6102.</p> <p>Understand this facility does not extend to club or reciprocal licences.</p> <p>Understand the purpose and function of the CEPT Harmonised Amateur Radio Examination Certificate (HAREC).</p> <p>Recall that many countries will offer reciprocal licences to UK amateurs with a HAREC Full licence and that operation is in accordance with the host country's rules.</p>
7H2			Identify the 3 ITU regions and recall that the frequencies are given in the ITU Radio Regulations

Part 2 – The Syllabus

	Section 8 – Safety		
	Electricity		
8A1	Recall that high voltages carry a risk of electrocution and high currents carry a risk of overheating and fire.	Understand that large or high-voltage capacitors can store dangerous electric charges and must be discharged before working on equipment. Recall that large value resistors can be used to provide leakage paths for these stored charges.	Recall that lethal voltages can exist in equipment and that live circuits may be exposed as soon as the equipment case is removed.
8A2	Recall that where a safety earth has been fitted it must not be removed. Recall that special care is needed with earthing arrangements and that a competent professional must be consulted prior to making any modifications.		Recall that in PME systems the main earth terminal is connected to the neutral of the electricity service at the consumers' premises. Recall that under severe fault conditions PME systems have the potential to cause fatal electric shocks and/or fires in amateur radio stations. Recall that the RF earth in an amateur station should be connected to the PME bonding point in accordance with the relevant requirements. Recall that any cross-bonding must be tested and recorded by a qualified professional. <i>Note: The relevant requirements may vary depending on the UK region and the practice of the Distribution Network Organisation concerned.</i>
8A3	Recall the correct way to wire a 3-pin mains plug.		

Part 2 – The Syllabus

<p>8A4</p>	<p>Recall that fuses to be fitted in accordance with manufacturer's instructions.</p> <p>Recall that a fuse is a thin wire designed to melt, breaking the circuit, when passing an excessive current.</p> <p>Recall that the reason for a blown fuse needs to be properly investigated.</p>	<p>Recall that equipment mains fuses may be of a special type, such as quick blow or slow blow to allow for an initial surge of current and that the specified type must be fitted.</p> <p>Understand that a fuse must be correctly rated for proper protection, and, in the absence of manufacturer's instructions, to select an appropriate fuse.</p> <p><i>For mains: current = power/230 where 230 is the nominal mains voltage.</i></p>	
<p>8A5</p>	<p>Understand that a Residual Current Circuit Breaker with Overcurrent protection (RCBO) will give better protection against electric shock than relying solely on a conventional fuse which only protects against excessive current.</p> <p><i>Note: The candidate should appreciate that an RCBO will detect currents to earth of about 30mA whereas a fuse will only blow at several amps and only when the fault is a short circuit (L-N or L-E).</i></p> <p><i>The candidate should also understand that contact with both live and neutral may result in fatal injury.</i></p> <p><i>The mechanics of RCBO operation (differential current sensing) is not examinable.</i></p>		
<p>8A6</p>	<p>Recall that work inside equipment should only be carried out with the power sources disconnected.</p> <p>Recall why it is important to follow manufacturer's instructions for servicing equipment.</p>	<p>Understand that working on live equipment must only be done if it is not practicable to do otherwise and if the risks and appropriate precautions are fully understood.</p>	<p>Understand that no work should be undertaken on live equipment unless it is not practicable to do otherwise.</p> <p>Understand that suitable precautions must be taken to avoid electric shock.</p>

Part 2 – The Syllabus

<p>8A7</p>	<p>Understand that all equipment should be controlled by a clearly marked master switch, the position of which should be known to others in the house or club.</p> <p>Recall that, in the event of an accident or fire involving electricity, the first action is to switch off the power.</p> <p>Recall that the casualty must not be touched unless the power has been switched off.</p>		
<p>8A8</p>	<p>Recall that some batteries can supply very high currents which can be hazardous if subjected to short circuit.</p> <p>Recall that battery charging must be in accordance with manufacturer instructions and that lithium batteries in particular can cause fire and explosion if not properly treated.</p> <p>Understand that different battery technologies require different charging techniques and must use the correct type of charger.</p>	<p>Understand that vehicle batteries are a source of very high currents which can start a fire and that battery contents are corrosive.</p> <p>Understand that explosive hydrogen gas can be given off when charging batteries and that ample ventilation is required.</p>	
	<p>Using tools</p>		
<p>8B1</p>	<p>Recall that eye protection must be worn when using tools to prevent eye damage from small metal particles (swarf).</p>		
<p>8B2</p>	<p>Recall that all tools, including power tools, can be hazardous and should be handled with care and appropriate precautions taken.</p>	<p>Understand that screwdrivers, drills, saws and files must be handled with care.</p> <p>Understand that fingers should always be behind the blade of hand tools.</p>	

Part 2 – The Syllabus

8B3		Understand that any items being drilled, sawn or filed must be securely held in a vice or similar device to prevent them slipping or rotating.	
8B4		Understand that any locking keys, and/or chuck keys, must be removed before using a power tool such as a drill to prevent the key being ejected at high speed.	
8B5		Understand that using a centre punch will help prevent a drill bit slipping.	
8B6		Understand the reasons why a bench-mounted pillar drill is safer than a hand-held drill.	
8B7	<p>Recall that eye protection must be worn when soldering to prevent solder or flux from splashing into the eyes.</p> <p>Recall that a soldering-iron stand must be used to avoid skin contact with the hot bit of the iron when not in use.</p> <p>Recall that soldering work stations must be well ventilated to avoid inhalation of solder fumes, which can cause breathing problems particularly to asthmatics.</p>		
	Working at height		
8C1	<p>Recall that antenna erection is potentially hazardous and that it is advisable to have someone to help you.</p> <p>Understand the need for at least one adult to be present.</p>		

Part 2 – The Syllabus

8C2	<p>Recall that a ladder should be used at the correct angle (4:1 height-to-base ratio).</p> <p>Understand that ladders must be adequately secured to prevent them slipping.</p> <p>Understand why it is important not to overreach from a ladder, to prevent falling off.</p>		
8C3	<p>Understand why, when working at height, a tool belt or similar device to carry tools should be used, and that it will help prevent falling objects.</p> <p>Understand the need to wear hard hats when working at height or when others are working at height.</p>		
	<p>Working with RF</p>		
8D1	<p>Recall that the main health effect of exposure to electromagnetic radiation is heating of body tissue and that the eyes are particularly susceptible to damage.</p>	<p>Recall that at 100W transmit power, especially with higher gain antennas, the EMF compliance distance can be several metres.</p> <p>Recall that, when mobile, pedestrians might be inside the EMF compliance distance.</p> <p>Recall that in such situations, especially when stationary, transmission must cease.</p>	<p>Recall that the International Commission for Non-Ionising Radiation Protection (ICNIRP) produces guidance for exposure to Radio Frequency fields.</p> <p>Understand it is not advisable to exceed the recommended safe exposure levels and that this is particularly applicable at locations open to the public.</p>
8D2	<p>Recall that guidance on safe levels of RF radiation is available from government and international bodies, Health Security Agency and the International Commission on Non Ionizing Radiation Protection (ICNIRP).</p>		
8D3	<p>Recall what a waveguide is and why it is unwise to look down a microwave frequency waveguide or to stand close to or in front of high-gain antennas as they may be in use.</p>		

Part 2 – The Syllabus

<p>8D4</p>	<p>Recall that antenna elements and other conductors carrying RF should not be touched whilst transmitting.</p> <p>Recall that antennas should be mounted where people will not come into accidental contact with them.</p> <p><i>Note: this does not apply to low powered devices such as hand-held equipment.</i></p>		
	<p>Lightning</p>		
<p>8E1</p>	<p>Recall that particularly high antennas may need special protection against lightning.</p> <p>Recall that the local authority building department may be able to offer advice.</p>	<p>Recall that limited protection of equipment against the build-up of static charge can be obtained from gas discharge arrestors, spark gaps and bleed resistors.</p>	<p>Recall that thunderstorms carry heavy static charges.</p> <p>Understand that the static charge from thunderclouds can ionise the air to form a low resistance path to ground, enabling a very high current to flow as a lightning strike.</p> <p>Understand the risks to human life, domestic property and electronic equipment associated with a direct strike and/or the build-up of static charges.</p> <p>Understand that there is little that can be done to protect an amateur station from a direct lightning strike, but that good static discharge systems can prevent dangerous static charges building up on antenna systems during thunderstorms.</p> <p>Understand that disconnecting antenna feeders from radio equipment also reduces the risks.</p>

Part 2 – The Syllabus

	Working mobile and portable		
8F1	<p>Recall that elevated wires, masts and antennas must be suitably located and secured.</p> <p>Recall that antennas and feeders must not be sited close to overhead power cables.</p> <p>Recall that a lethal electric shock can result from antennas and ladders coming into contact with or attracting arcing from overhead lines.</p>		
8F2	<p>Understand the reasons for not having wires trailing across the floor, trip hazards and the risk of frayed insulation.</p>		
8F3	<p>Recall that excessive volume when wearing headphones can cause damage to hearing.</p>		

Part 2 – The Syllabus

<p>8F4</p>	<p>Recall that operating in temporary premises and/or outdoors can introduce new hazards e.g. temporary mains connections, trailing cables, damp ground.</p> <p>Recall the additional safety precautions that should be taken whilst operating in temporary premises and/or outdoors e.g. risk assessment, cable routing, protection, correct fusing, use of RCBO's, no adjustments or repairs to live equipment.</p> <p>Recall that advice should be sought where you are unsure.</p>		<p>Understand that operating in temporary premises and/or outdoors can introduce new hazards i.e. overhead power lines, inadequate electrical supplies, trailing cables, damp ground and excessive field strengths.</p> <p>Recall the additional safety precautions that should be taken whilst operating in temporary premises and/or outdoors i.e.</p> <ul style="list-style-type: none"> • site survey/risk assessment, • cable routing/protection, • correct fusing, • use of Residual Current Devices (RCD's, RCBO's) • no adjustments or repairs to live equipment. <p>Recall that mains supplies in other countries may be of a different voltage or frequency; utilise different plugs and sockets and that UK specified equipment may not be suitable or hazardous if connected and used.</p>
<p>8F5</p>	<p>Recall that safety is everybody's responsibility and that one must be alert to any potentially unsafe circumstance, warn others and report the matter to the appropriate person.</p> <p>Recall this equally applies in your own 'shack' and when entertaining visitors.</p>		<p>Understand that operating when mobile or maritime mobile can introduce new hazards i.e. insecure equipment, long/flexible antennas, accidental shorts to earth, lack of attention to driving.</p> <p>Recall the additional safety precautions that should be taken whilst operating mobile and/or maritime mobile i.e. secure equipment, cable routing/ protection, correct fusing, use of hands free equipment, attention to good radio housekeeping.</p>

Part 2 – The Syllabus

8F6			<p>Understand that a risk assessment should be performed when an activity could present a hazard to yourself or others.</p> <p>Understand that risk assessment involves identification of hazards and the measures to mitigate the risk.</p> <p>Recall a risk assessment needs to consider the likelihood of harm and the severity of that harm. Recall that the significant findings of risk assessments need to be recorded.</p> <p>Recall that risk assessment records are important in law and for insurance purposes. Recall that risks should be expressed in understandable terms.</p> <p>Recall that appropriate insurances should be obtained for all amateur radio activities but in particular where the public could be involved.</p>
8F7			<p>Understand the risks associated with the use of electrical generators, earthing, fuel stowage, refilling.</p>

Part 2 – The Syllabus

	Section 9 – Measurements and construction		
	Measurements		
9A1		Recall the purpose of a multimeter and understand how to set the meter to the correct range and polarity before connecting to the circuit.	Understand the use of series multiplier resistors in analogue voltmeters and shunts in ammeters. Understand the effect of the test meter on the circuit under test.
9A2		Understand that voltmeters have a high internal resistance so that they draw minimal current from the circuit under test. Understand that ammeters have a low internal resistance so that they minimise the voltage loss to the circuit under test. Understand that a voltmeter is always connected in parallel with a component or circuit being tested. Understand that an ammeter is always connected in series with a component or circuit being tested.	
9A3		Understand the advantages and disadvantages of analogue and digital displays and be able to read analogue and digital values.	Understand the effect of measurement tolerance, calibration accuracy and time related drift on frequency measurements and the allowances to be made for transmission bandwidths.

Part 2 – The Syllabus

9A4			<p>Understand that signal generators and similar devices will have a source impedance and the effect on the signal level of attaching different load impedances.</p> <p>Recall that not all measuring equipment will have a 50Ω input impedance.</p> <p>Understand that the choice of measuring equipment may have an effect on the on the measurement result and on the object under test.</p>
9A5		<p>Understand the use of voltmeters and ammeters to determine the power applied to a circuit.</p>	<p>Understand that steady RF power may be determined by measuring the RF potential difference across a dummy load and that a steady audio signal, e.g. from an audio oscillator, will be required for AM and SSB measurements.</p> <p>Understand the meaning of peak envelope power (PEP) of an SSB transmission and that it may be determined using a peak reading power meter or an oscilloscope and dummy load.</p>
9A6			<p>Recall the uses and limitations of crystal calibrators, digital frequency counters and standard frequency transmissions.</p>
9A7			<p>Identify the circuit of an SWR meter using either a sense wire between the inner and outer conductors of a coaxial line or a current transformer and capacitive voltage tap.</p> <p>Understand in simple terms how this leads to an SWR reading on devices using a single meter, twin meters or cross-needle twin meter.</p>

Part 2 – The Syllabus

9A8			<p>Understand the purpose and basic operation of an oscilloscope.</p> <p>Calculate the frequency and voltage of a waveform from given data.</p>
9A9			<p>Understand the purpose and basic operation of a spectrum analyser.</p> <p>Identify the fundamental and harmonics on a typical spectrum analyser display.</p>
	Decibels		
9B1		<p>Recall that decibels are a power ratio.</p> <p>Recall that a power gain of 3 dB equates to doubling the power and 10dB equates to a power increase of times 10.</p> <p>Calculate the power gain or loss of various dB ratios based on 3 and 10dB and their multiples. This includes examples such as 25W is equivalent to 14dBW.</p> <p>Recall that dB gains and losses in a system can be added to find the total gain or loss in the system.</p> <p>Recall the meaning of:</p> <ul style="list-style-type: none"> • dBW (comparison with 1 W) • dBi (comparison with an isotropic radiator) and • dBd (comparison with a half wave dipole). 	<p>Use the equations for decibel power, dB, dBW, dBm and voltage ratios dBV.</p>

Part 2 – The Syllabus

	Components		
9C1		<p>Recall the resistor colour code, colours 0 to 9 with gold as multiplier.</p> <p>Recall silver (10%) and gold (5%) as tolerance bands.</p> <p>Identify the value of a resistor between 1Ω and 9MΩ from the E12 series.</p> <p>Recall how to read both 4 band and 5 band resistors.</p> <p>Recall how to read components with a numeric marking of the format 4R7, 3k3 or for capacitors, 103.</p> <p><i>Note: The resistor colour code will be provided and actual encoding or decoding of colours will be either 4 band or 5 band resistors.</i></p> <p><i>Candidates are not expected to know the values of the E12 series.</i></p>	<p>Recall that temperature has an effect on the value of components. Those with negative coefficients will reduce in value as temperature rises whereas those with positive coefficients will increase in value.</p> <p>Understand the effect this will have on tuned circuits and remedial measures.</p> <p><i>Questions may include simple calculations.</i></p>
	Construction		
9D1		<p>Recall that screening with thin metal sheet is effective in reducing unwanted radiation from equipment and/or between stages within equipment.</p>	
	Soldering		
9E1		<p>Understand that soldering is a method of joining metal wires and components using solder and a hot soldering iron.</p>	

Part 2 – The Syllabus

9E2		Recall that solder is a low melting point alloy and that many solders contain a flux to help the solder to flow and to prevent a layer of oxide forming on the surfaces to be joined.	
9E3		Recall that some metals are easier to solder than others.	
9E4		Understand that the tip of the soldering iron has to be cleaned to help remove any oxide and then tinned to prevent the oxide re-forming and to improve the conduction of heat to the joint. Recall the reason for tinning wires prior to soldering.	

Part 3 – Foundation Licence Examination Material

Table 1. Symbols.

Description	Symbol
Cell	
Battery	
Fuse	
Lamp (incandescent)	
Light Emitting Diode LED	
Resistor	



Description	Symbol
Switch s.p.s.t.	
Antenna	
Earth	
Microphone	
Loudspeaker	

Part 3 – Foundation Licence Examination Material

Table 2. Diagrams.



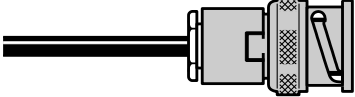
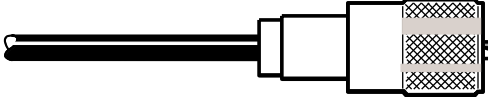
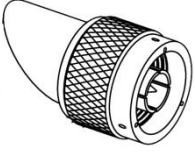
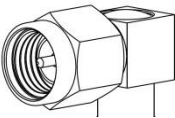
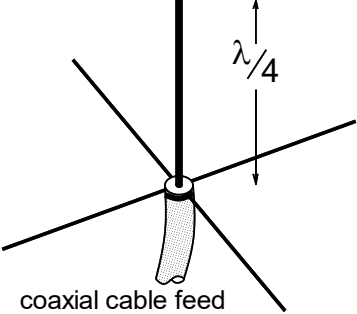
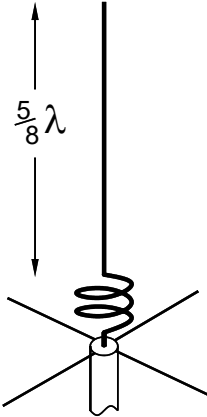
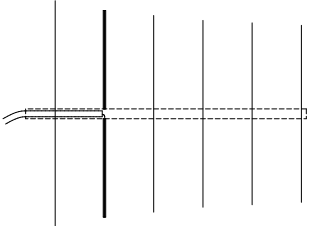



<p>Analogue transmitter. The block diagram shown will be used for all assessment questions. It is not intended that the blocks will relate to any particular architecture of radio, merely the basic functions that need to be performed. The symbols for the microphone and antenna should also be known.</p>	
<p>The block diagram shown will be used for all assessment questions. It is not intended that the blocks will relate to any particular architecture of radio, merely the basic functions that need to be performed. The loudspeaker symbol should be known.</p>	
<div style="display: flex; justify-content: space-around;"> <div style="text-align: center;"> <p><i>AM</i></p> </div> <div style="text-align: center;"> <p><i>FM</i></p> </div> </div> <p><i>Note different AM depths of modulation may be used.</i></p>	<p><i>Note different bandwidths may be used.</i></p>
<p>CW signal envelope</p>	
<p>Digital Transmitter. A to D is an analogue to digital converter. D to A is a digital to analogue converter.</p>	
<p>Digital Receiver.</p>	



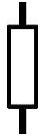

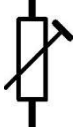
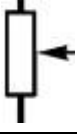

Part 3 – Foundation Licence Examination Material

<p>BNC</p> 	<p>PL259</p> 
<p>N</p> 	<p>SMA</p> 
<p>$1/4 \lambda$ ground plane, <i>Note: Exam questions will not show the dimensions.</i></p>  <p style="text-align: center;">coaxial cable feed</p>	<p>$5/8 \lambda$ ground plane <i>Note: Exam questions will not show the dimensions.</i></p> 
<p>Yagi</p> 	<p>Dipole</p> 

Part 4 – Intermediate Licence Examination Material

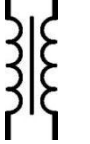
Table 3. Symbols

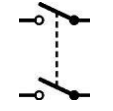
Description	Unit	Symbol
Resistor	Ohm Ω	
Variable resistor		
Pre-set resistor		
Potentiometer		
Capacitor	Farad F	
Polarised capacitor		
Variable capacitor		

Description	Unit	Symbol
Inductor	Henry H	
Iron cored inductor		
Transformer		
Lamp		
Switch single pole, single throw (s.p.s.t.)		
double pole, single throw (d.p.s.t.)		
Antenna		

Part 4 – Intermediate Licence Examination Material

Description	Unit	Symbol
Cell	Volt	
Battery		
Fuse		
Crystal	Hertz Hz	
Semiconductor diode		
Light emitting diode (LED)		
Variable capacitance diode		

Description	Unit	Symbol
Chassis		
Earth		
Microphone		
Loudspeaker		
Earphone		
Field effect transistor (FET) <i>Note that the circle is optional</i>		
Transistor (NPN) <i>Note that the circle is optional</i>		

Part 4 – Intermediate Licence Examination Material

Table 3b Diagrams

<p>Crystal diode receiver with headphones</p>	
<p>Direct Conversion Receiver</p> <p><i>Note: The Carrier Insertion Oscillator may alternatively be portrayed as a Beat Frequency Oscillator as required.</i></p>	
<p>Superhet Receiver</p> <p><i>Note: The Carrier Insertion Oscillator may alternatively be portrayed as a Beat Frequency Oscillator as required.</i></p> <p><i>There may be more than one Intermediate Frequency stage and the RF amplifier stage may be omitted as required. AGC may or may not be shown.</i></p>	

Part 4 – Intermediate Licence Examination Material

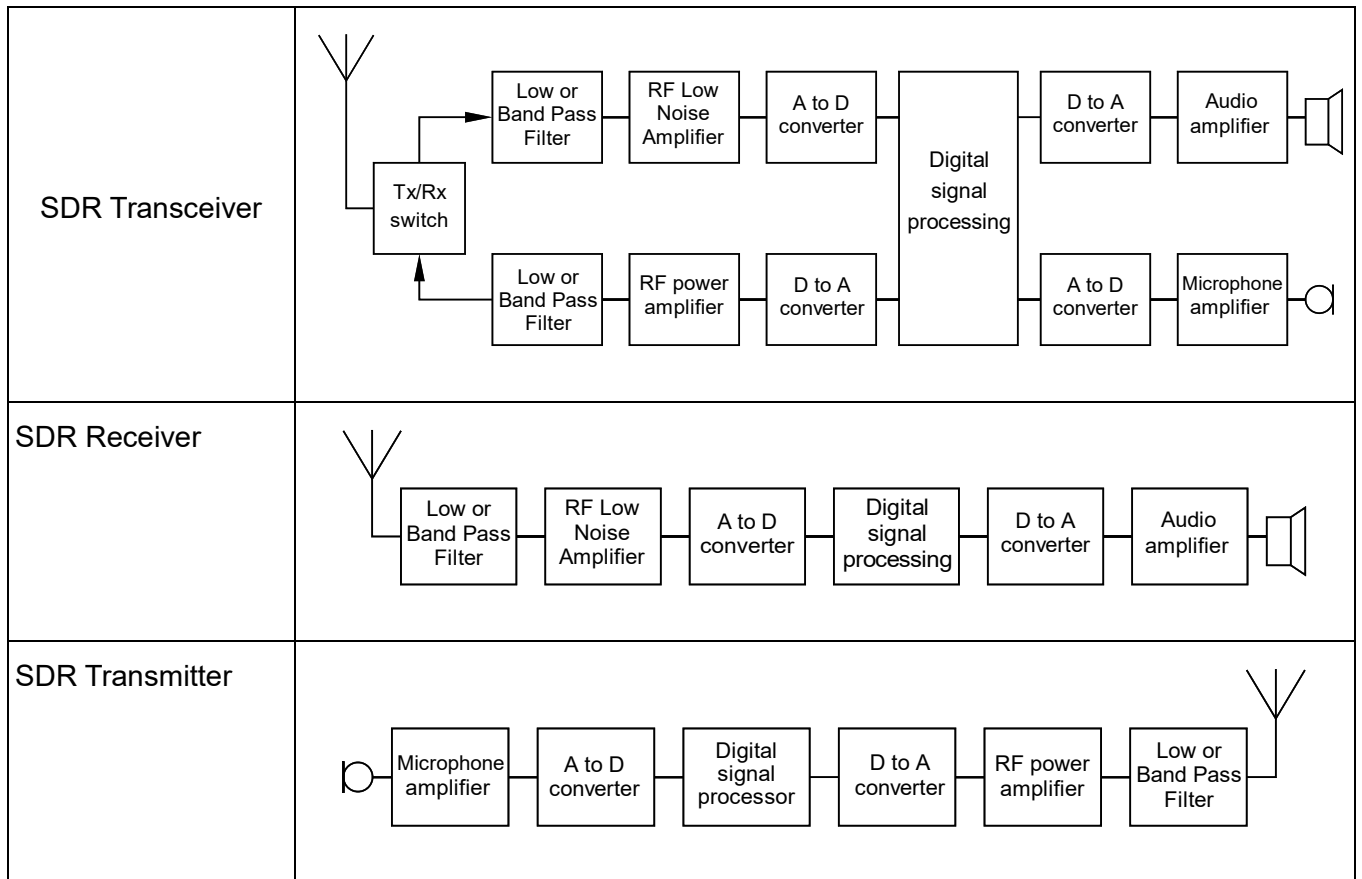

Part 4 – Intermediate Licence Examination Material

Intermediate Formula sheet







This formula sheet will be provided to candidates in the Intermediate examination and may be used to answer any question.



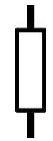

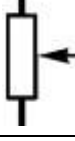

Ohm's Law $V = I \times R$		Power $P = V \times I$
Series $R_T = R_1 + R_2 + R_3$		Parallel $\frac{1}{R_T} = \frac{1}{R_1} + \frac{1}{R_2} + \frac{1}{R_3}$
Potential divider $V_{out} = V_{in} \frac{R_2}{R_1 + R_2}$		
Series $\frac{1}{C_T} = \frac{1}{C_1} + \frac{1}{C_2} + \frac{1}{C_3}$		Parallel $C_T = C_1 + C_2 + C_3$
Series $L_T = L_1 + L_2 + L_3$		Parallel $\frac{1}{L_T} = \frac{1}{L_1} + \frac{1}{L_2}$
AC $V_{rms} = \frac{V_{peak}}{\sqrt{2}} V_{rms} = \frac{V_{peak}}{\sqrt{2}}$		AC $t = \frac{1}{f}$
Inductor $X_L = 2\pi fL$		Capacitor $X_C = \frac{1}{2\pi fC}$
Tuned circuit $Q = \frac{f_C}{f_U - f_L} = \frac{\text{centre frequency}}{\text{bandwidth}}$		
Transformer $V_S = V_P \times \frac{N_S}{N_P}$		Transformer $I_S = I_P \frac{N_P}{N_S}$
Transistor $I_C = \beta \times I_B$		
Velocity of radio waves in free space $v = 3 \times 10^8 \text{ m/s} = 300,000,000 \text{ m/s}$		Frequency & wavelength $v = f\lambda$
antenna $erp = power \times gain$ (linear)		

Resistor Colour Code			
Black	0	Blue	6
Brown	1	Violet	7
Red	2	Grey	8
Orange	3	White	9
Yellow	4	Silver	10%
Green	5	Gold	5% or $\div 10$

Part 5 – Full Licence Examination Materials

Table 4. Symbols.

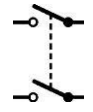
Description	Unit	Symbol
Resistor	Ohm Ω	
Variable resistor		
Pre-set resistor		
Potentiometer		
Capacitor	Farad F	
Polarised capacitor		
Variable capacitor		
Description	Unit	Symbol

Description	Unit	Symbol
Inductor	Henry H	
Iron cored inductor		
Transformer		
Lamp		
Switch single pole, single throw (s.p.s.t.)		
double pole, single throw (d.p.s.t.)		
Antenna		
Description	Unit	Symbol

Part 5 – Full Licence Examination Materials

Cell		
Battery	Volt	
Fuse	Amp	
Crystal	Hertz Hz	
Semiconductor diode		
Light emitting diode (LED)		
Variable capacitance diode		

Chassis	
Earth	
Microphone	
Loudspeaker	
Earphone	
Field effect transistor (FET) <i>Note that the circle is optional</i>	
Transistor (NPN) <i>Note that the circle is optional</i>	

Part 5 – Full Licence Examination Materials

Formula sheet This formula sheet will be provided to candidates in the Full Licence examination.

$R_T = R_1 + R_2 + R_3$	$\frac{1}{R_T} = \frac{1}{R_1} + \frac{1}{R_2} + \frac{1}{R_3}$	$V = IR$
$V_{out} = V_{in} \frac{R_2}{R_1 + R_2}$	$P = IV = \frac{V^2}{R} = I^2R$	$V_{rms} = \frac{V_{peak}}{\sqrt{2}}$
$\frac{1}{C_T} = \frac{1}{C_1} + \frac{1}{C_2} + \frac{1}{C_3}$	$C_T = C_1 + C_2 + C_3$	$C = \frac{k_A}{d}$ where $k = \epsilon_0 \epsilon_r$
$L_T = L_1 + L_2 + L_3$	$\frac{1}{L_T} = \frac{1}{L_1} + \frac{1}{L_2} + \frac{1}{L_3}$	$X_L = 2\pi fL$
$Z = \sqrt{R^2 + X^2}$	$V_T = \sqrt{V_R^2 + V_C^2 (or V_L^2)}$	$X_C = \frac{1}{2\pi fC}$
$f = \frac{1}{2\pi\sqrt{LC}}$	$t = \frac{1}{f}$	$t = CR$
$Q = \frac{2\pi fL}{R} or \frac{1}{2\pi fCR}$	$Q = \frac{f_c}{f_U - f_L} = \frac{\text{centre frequency}}{\text{bandwidth}}$	$R_D = \frac{L}{CR}$
$Q = 2\pi fCR_D$	$bw = 2(AF_{max} + \Delta f)$	
$V_S = V_P \frac{N_S}{N_P}$	$I_P = I_S \frac{N_S}{N_P}$	$Z_P = Z_S \left(\frac{N_P}{N_S}\right)^2$
$I_C = \beta I_B$	$f_{step} = \frac{f_{crystal}}{A}$	$f_{out} = f_{crystal} \frac{N}{A}$
$v = 3 \times 10^8 \text{ m/s}$	$E = \frac{7 \sqrt{erp}}{d} = \frac{5.5 \sqrt{eirp}}{d}$	$SWR = \frac{V_{max}}{V_{min}} = \frac{V_f + V_r}{V_f - V_r}$
$v = fl$	<i>erp</i> = power ' gain (wrt dipole) <i>eirp</i> = power ' gain (isotropic)	$Z_0^2 = Z_{in} \times Z_{out}$
$Gain(loss) = 20 \text{Log}_{10} \frac{V_{out}}{V_{in}} \text{ dB}$	$Return \ loss = 10 \text{Log}_{10} \frac{\text{Incident power}}{\text{Reflected power}} \text{ dB}$	
$Gain (loss) = 10 \text{Log}_{10} \frac{P_{out}}{P_{in}} \text{ dB}$	$Gain = 10 \text{Log}_{10} \frac{\text{Power from Yagi}}{\text{Power from dipole}} \text{ dBd}$	
$Gain (loss) = 10 \text{Log}_{10} \frac{P_{out}}{P_{in}} \text{ dB}$	$Gain = 10 \text{Log}_{10} \frac{\text{Power from Yagi}}{\text{Power from isotropic}} \text{ dBi}$	